

BID PACKET TABLE OF CONTENTS



Knowledge that helps.
Homes that fit.

| | Pages |
|-----------------------------------|--------------|
| 1- Bid Invite – | 2 |
| 2- Bid Section List | 3 |
| 3- Bid Form | 4 |
| 4- Non-Collusion Affidavit | 5 |
| 5- PRG New Construction Spec Book | 6-32 |
| 6- Plans | 33-40 |
| 7- Proposed Site and Grading Plan | 41 |
| 8- Existing Conditions Survey | 42 |
| 9- Soils-Shoring Report | 43-62 |

May 13, 2024



Knowledge that helps.
Homes that fit.

PRG Inc. as Developer, and Benoz Enterprises performing as General Contractor, are accepting bids from sub-contractors and suppliers for the construction of five new single-family infill homes located at: **1000 30th Ave. North, 1818 Sheridan Ave. North, 2203 Oliver Ave. North, 2317 3rd St. North, and 2709 Humboldt Ave. North, Minneapolis, MN 55411.**

Section 3 Businesses and Minority and Women-owned Business Enterprises are encouraged to bid. See bid documents for the Divisions/Sections for which bids are being sought.

Copies of the bid documents – bid invite, bid section list, bid form, non-collusion affidavit, spec book, plans, site plan, survey and soils report - are available via the PRG website – <https://www.prginc.org/contractor-bids> Arrangements can also be made for pick up at the PRG office – 2017 East 38th Street, Minneapolis MN 55407.

Selection of subcontractors and suppliers will be based on but not limited to the following criteria: Price, references and demonstrated experience with this type of work, ability to perform within the time frame, compliance with Section 3 if applicable, compliance with the Small and Underutilized Business Enterprise Program (SUBP) hiring goals, if applicable, are licensed and insured, in good standing with the Minnesota Dept. of Labor and Industry and are not on US Government/HUD or State of Minnesota Dept. of Administration Suspended/Debarred Vendor list.

Bids must be received by 1:00 PM, May 30, 2024 at the offices of PRG, Inc. 2017 E. 38th St. Minneapolis, MN 55407. Please submit bids using the provided bid forms. Upload completed bid forms via the PRG website or via email prg@prginc.org

For any bidding questions call/email Benjamin Akhigbe of Benoz Enterprises at 612-508-7927 / bakhigbe@aol.com or Kevin Gulden at PRG – 612-721-7556 ext. 130 / kevin@prginc.org or Caliyah Rush at PRG – 612-721-7556 ext 210 / caliyah@prginc.org

PRG reserves the right to reject any and all bids and waive informalities in the bidding process.

PRG Infill Single Family New Construction - Mpls Homes Round 4

**Projects: 1000 30th Ave. North, 1818 Sheridan Ave. North, 2203 Oliver Ave. North,
2317 3rd St. North and 2709 Humboldt Ave. North**

Owner: PRG, Inc.

General Contractor/Builder: Benoz Enterprises

PRG and Benoz Enterprises are seeking sub-contractor bids for the following Division/Bid Sections:

Use the bid form provided to submit a bid

You may bid on more than one bid section if you so choose and more than one project.

Fill out a separate bid form for each bid and each project.

See copy of PRG spec book and plans for more detail of each bid section.

BID DIVISION/SECTIONS

2300 Excavation/ Backfill/ Grading/Erosion Control

2450 Landscaping

2500 Water and Sewer Service

3100 Foundation

3150 Foundation Waterproofing

3200 Concrete Flatwork

4200 Masonry Block

6100 Rough Carpentry - Framing (Labor Only)

7300 Roofing (Labor Only)

7640 Siding/ Trim/ Soffit/ Fascia (Labor Only)

7660 Insulation & Air Sealing

9200 Drywall & Backerboard

9300 Painting - Exterior & Interior

9400 Woodwork / Finish Carpentry (Labor Only)

9600 Flooring - Tile/ Vinyl Plank/ Carpet

15100 Heating / Cooling / Ventilation

15500 Plumbing

16100 Electrical - Wiring/Switches & Outlets/ Light Fixtures

BID FORM – 1000 30th Ave./1818 Sheridan/2203 Oliver/2317 3rd St/2709 Humboldt

DUE: 1:00 PM May 30, 2024

TO: Benoz Enterprises & PRG Inc.

FROM: COMPANY NAME: _____

ADDRESS: _____

PHONE: _____ **EMAIL:** _____

CONTACT PERSON: _____

1. The undersigned, having examined the proposed bid documents for the projects 1000 30th Ave North, 1818 Sheridan Ave. North, 2203 Oliver Ave. North, 2317 3rd St. North and 2709 Humboldt Ave. North and having visited the sites and examined the conditions affecting the Work, hereby proposes and agrees to furnish required labor, materials, and equipment, and to perform operations necessary to complete the work as required by the Specifications, Drawings, and bid documents for that portion of the work identified as:

2. **PROJECT ADDRESS:**
(ex. 2709 Humboldt)

3. **DIVISION/SECTION #:**
(ex. 9300-Painting- Ext & Interior)

4. **BID AMOUNT:** \$

5. The undersigned includes the following items in addition to the Bid Form:
A. Evidence of insurance or evidence of ability to acquire adequate insurance for the project.
B. Non-collusion Affidavit

BIDDER _____
By _____
Address _____

Signature _____

Type of business entity: _____
(corporation, Co-partnership, individual, etc.)

Organized under the laws of the State of _____

Officers of the Corporation: _____

Bid date this _____ day of _____, 2024

PRG, Inc.
Non-collusion Affidavit of Prime Bidder

Contract No. _____

State of Minnesota)
County of Hennepin) ss

_____, being first duly sworn, deposes
and says that:

1) He is _____
(owner, partner, officer, representative or agent)
of _____, the Bidder that has submitted
the attached Bid:

2) He is fully informed respecting the preparation and contents of the attached Bid and of
all pertinent circumstances respecting such Bid:

3) Bid is genuine and is not a collusive or sham Bid:

4) Neither the said Bidder nor any of its officers, partners, owner, agents, representative,
employees or parties in interest, including this affiant, has in any way colluded,
conspired, connived or agreed, directly or indirectly, with any other Bidder, firm or
person to submit a collusive or sham Bid in connection with the Contract for which the
attached Bid has been submitted or to refrain from bidding in connection with such
Contract, or has in any manner, directly or indirectly, sought by agreement or collusion or
communication or conference with any other Bidder, firm or person to fix the price or
prices in the attached Bid or of any other Bidder, or, to fix any overhead, profit or cost
element of the bid price of any other Bidder, or to secure through any collusion,
conspiracy, connivance or unlawful agreement any advantage against PRG or any person
interested in the proposed Contract; and

5) The price or prices quoted in the attached Bid are fair and proper and are not tainted by
any collusion, conspiracy, connivance or unlawful agreement on the part of the Bidder or
any of its agents, representatives, owners, employees, or parties in interest, including this
affiant.

(Signed) _____

(Title)

Subscribed and sworn to before me

This _____ day of _____, 20____

(Notary Public)

My Commission Expires _____

PRG
New Construction
Spec Book

INFILL SINGLE FAMILY HOMES

Folk Plan
Humboldt Plan

Locations:
1000 30th Ave. North
1818 Sheridan Ave. North
2203 Oliver Ave. North
2317 3rd Street North
2709 Humboldt Ave. North

Minneapolis, MN 55411

May 2, 2024

GENERAL CONDITIONS

A. These specifications are in short outline form. All materials shall be installed according to the manufacturer's printed directions and/or industry standards. All materials furnished and work done under this contract shall comply with the building, electrical, plumbing and other applicable codes of the municipality in which the work is performed.

The general conditions herein set forth shall apply to any contract given under these specifications and shall be binding upon every Sub-contractor as well as the General Contractor.

The surveys, plans, elevations, sections and detail drawings, together with these specifications, are to form the basis of the contract; where discrepancies in the spec are found the higher quality or greater quantity shall be provided.

B. Contact Kevin Gulden or Kathy Wetzl-Mastel at 612-721-7556 or kevin@prginc.org with questions about the bid documents and to report any discrepancies between the plans and specifications. Scaled and dimensioned plans are available for review at:

PRG Inc.
2017 E. 38th Street
Minneapolis, MN 55407

SUPPLEMENT TO GENERAL CONDITIONS:

PRG Infill Single Family Homes

PROJECT INFORMATION

PROJECT ADDRESSES-

1000 30th Ave. North, Mpls
1818 Sheridan Ave. North, Mpls
2203 Oliver Ave. North, Mpls
2317 3rd St. North, Mpls
2709 Humboldt Ave. North

OWNER & DEVELOPER

PRG Inc.
2017 E. 38th Street
Minneapolis, MN 55407
Contact: Kevin Gulden (kevin@prginc.org)
Caliyah Rush (caliyah@prginc.org)
Phone: 612-721-7556

ENERGY-HERS RATER / ENERGY CONSULTANT

Building Knowledge Inc.

PO Box 1376
Burnsville, MN 55337
Contact: Pat O'Malley
Phone: 612-597-4260
Email: pato@buildingknowledge.com

ATTACHMENTS

- Attachments are incorporated into this document by reference.
- ATTACHMENT A: General Project Information
 - ATTACHMENT B: Contracting & Workforce Participation Goals (Funding Requirement)
 - ATTACHMENT C: MN Green Communities Criteria Intended Methods Worksheet (2023-2024 Overly to the 2020 GC criteria)
 - ATTACHMENT D: Sworn Construction Statement
 - ATTACHMENT E: Section 3 Clause
 - ATTACHMENT F: Minneapolis Residential Construction Management Agreement
 - ATTACHMENT G: Geotechnical – Soils and Shoring Report
 - ATTACHMENT H: Notice to Proceed
 - ATTACHMENT I: Change Order Form
 - ATTACHMENT J: Indoor air PLUS Version 1 (Rev. 04) Verficiation Checklist
 - ATTACHMENT K: DOE Zero Energy Ready Home Version 2 (Rev 1)(ZERH) Program Requirements
 - ATTACHMENT L: Energy Star Single-Family New Homes Version 3.2 (Rev.13) Prog. Requirements

NOTICE TO PROCEED: The Notice to Proceed shall be issued only after the following are received and approved by the Owner: Sworn Construction Statement and Certificate of Insurance. No work shall begin prior to issuance of Notice to Proceed and obtaining proper permits.

PRE-CONSTRUCTION MEETING: A Pre-construction meeting shall be held with the General Contractor, Site Supervisor, Architect, and the Owner within the first 2 weeks of notice to Proceed.

CONSTRUCTION PROGRESS MEETINGS: Construction progress meetings may take place on occasion on-site or at an alternate location. Such meetings are to be announced one week in advance during the construction period.

WALK-THROUGHS: In addition to the inspections required by code, two walk-throughs are required. In order to assist with scheduling, Contractor is to notify Owner that the work is ready a minimum of three (3) days before a walk-through is scheduled. Required walk-throughs:

- 1.) Framing, structural walk-through: after all framing/structural work is complete and before it is covered by insulation or finishes. Contractor shall make necessary framing changes (if any) as noted by engineer /architect during walk-through.
- 2.) Insulation walk-through: after insulation is installed and before it is covered by finishes. Contractor shall reinforce or reinstall insulation if required by energy rater/consultant.

TIME SCHEDULE: **All work shall be completed within 150 continuous days**, starting with the date of Notice to Proceed. With the exception of seasonal/weather-dependent work, (ie exterior concrete work) work not completed in 150 days shall be subject to liquidated damages per the Construction Contract. Requests for additional time due to factors outside the contractor's control must be detailed and approved via change order. Project completion is defined as issuance of the Certificate of Occupancy (CO) and all permits signed off by City of Minneapolis, State of MN electrical permit sign off, receipt of all full and final lien waivers including subcontractors and all site work and punchlist items completed.

CONTRACT: The form of Construction **Contract will be AIA Document A105-2007, Standard Form of Agreement between Owner and Contractor for** a Residential or Small Residential Project.

CHANGE ORDERS: No changes in the Work shall be allowed or compensated without a properly written and approved Change Order Proposal and Change Order using attached forms (ATTACHMENT I) as a template an electronic version can be made available. Changes made or substitutions installed without prior written approval by Owner shall be cause for replacement at Contractor's expense. Contractor may submit an alternate change order form if approved by owner.

PAYMENT REQUESTS: Each draw request for payment shall include the following documents: AIA Form G702 (Application & Certification for Payment), all relevant invoices to be paid (from both general contractor and all subs/suppliers) and the corresponding partial or full lien waivers. Please submit originals or legible copies with no white-outs or cross-outs. Draws shall be for work completed and products or materials installed. Purchased and/or on-site materials may be considered in payment if required documentation is submitted and certified by the Owner and Architect. 5% retainage on draws. Final Payment shall be issued only after the Owner receives a copy of the Certificate of Occupancy from the City of Minneapolis and all punch list items corrected and or addressed.

PERMITS: The General Contractor (and subcontractors as applicable) shall obtain all required permits and inspections. Contractor to provide Developer with copies of all permits and stamped plans upon request. Contractor and subcontractors are responsible for a permit fees and permit application fees.

DIVISION 1 – REQUIREMENTS

GENERAL REQUIREMENTS

PERMITS: The General Contractor (and subcontractors as applicable) shall obtain all required permits and inspections. Copies of stamped/signed plans: one to be submitted to the Owner and the other to remain on site at all times.

General Contractor to comply with all items/terms/conditions of the Minneapolis Residential Construction Management Agreement (CMA) (Hours of Operation/Noise Reduction/Approved Plans/Contact Information/Neighbor Notification/Dumpster and Street Use/Debris-Dumpster Maintenance/Building Materials-Deliveries/Idling of Vehicles/Crew Parking/Site and Surrounding Maintenance/Tracking Dirt/Dust Control/Winter Conditions/Restrooms-Portable Toilets/Damage to Public Property/Protection of Adjoining Property/Tree Protection/Survey/Erosion-Sediment Control/Changes to Site Plan and Complaints-Log. Any fines/citations resulting from a failure to comply with the terms of the CMA are the sole responsibility of the General Contractor.

CODES & STANDARDS: All work shall be in accordance with and conform to these codes, standards, requirements and regulations: Minnesota State Building Code, Minneapolis Housing Maintenance Code, Minneapolis Inspections Dept., the Minnesota and Minneapolis Health Departments. Minnesota Residential Energy Code – 2012 IECC.

ENERGY-EFFICIENCY REQUIREMENTS: The project will need to meet the 2023-24 MN Overlay to the 2020 Enterprise Green Communities Criteria, follow Energy Star New Homes Version 3.2 (Rev 12) target home recommendations, meet Indoor airPLUS Version1 (Rev. 4) specifications/guidelines and achieve DOE Zero Energy Ready Homes (ZERH) Version 2 certification. Failure to meet requirements will result in additional work and performance testing at contractor's expense. (<http://www.greencommunitiesonline.org/tools/criteria/index.asp>) General contractor is to work as a partner with Owner/Project Manager and Energy Consultant (Building Knowledge Inc.) to meet these requirements.

DONATED MATERIALS & OWNER PROVIDED MATERIALS: Materials provided by the Owner will be made ready for the General Contractor when needed. It will be the responsibility of the General Contractor to coordinate with the Owner and supplier to make sure all materials get to the site in a timely manner and installed as specified.

SAFETY & SECURITY: The General Contractor is responsible for the safety and security of the site. All contractors and workers shall take all necessary precautions, including complying with applicable Federal and Minnesota health and safety codes and regulations. All house and garage doors and windows shall be locked when the house is unoccupied, securing the house and garage against unintended entry. Contractor to notify owner when ready to have security system installed at owner's cost. Contractor responsible for all false alarm charges/fines from City of Minneapolis that result from improper use by contractor or sub-contractors from date of Notice to Proceed until Certificate of Occupancy is issued.

UTILITIES: Contractor is responsible for all utility charges from date of Notice to Proceed through the issuance of Certificate of Occupancy. If necessary PRG will pay utilities on behalf of the contractor during the construction period. A deduct change order in an amount equal to the utilities paid by PRG on behalf of the contractor will be executed at project closeout.

SITE MAINTENANCE: The Contractor is responsible for lawn mowing and snow removal of public sidewalk and is responsible for any fines or citations from the City of Minneapolis or penalties resulting from a failure to do so. Contractor is also responsible for snow removal of the private sidewalks and driveway at the site during construction. If the contractor fails to remove the snow or mow the lawn per the contract PRG reserves the right to hire third party and bill the contractor for these services. Contractor is responsible for watering and maintaining healthy lawn/sod for 30 days after installation. After 30 days Owner will inspect condition of sod and determine if any needs to be replaced at General Contractor's expense. Contractor shall provide an on-site portable restroom and follow City of Mpls requirements pertaining to.

ADJACENT PROPERTIES: Any damage to adjacent private property shall be repaired at the General Contractor's expense and in a timely manner. General Contractor and excavation sub-contractor are responsible for cost and installing necessary shoring/retention to avoid damage to neighboring property. Neighbors must receive prior notice and give permission for any work requiring access to their property. Clean up any construction debris on adjacent private or public property daily.

PATCHING: Each Subcontractor shall advise the General Contractor of the need and extent of patching that will be required for the proper execution of their respective work. The General Contractor shall be responsible for patching areas to match adjacent finished surfaces that result from other trades doing their work but are not the direct responsibility of a particular Subcontractor.

QUALITY CONTROL: General Contractor and all Subcontractors are to be familiar with the entire Specifications book and all plans/drawings and the work of others that may affect their own. Field verify all dimensions, sizes, elevations, and other existing conditions in the Specifications and on Plans/Drawings; report any discrepancies upon discovery to Owner and Architect. Surfaces and substrates shall be clean, smooth, plumb and level and properly prepared prior to applying finish materials; repair, reinforce or replace as necessary any missing or deteriorated surface or substrate. Cover and protect all finished surfaces (floors, counters, fixtures, etc.) during construction. General Contractor is responsible for final cleaning. (See FINAL CLEAN-UP section below.) All labor is to be performed in a "workman-like" manner, consistent with industry & trade standards and practices of the Metro area, and with manufacturers' installation instructions. All products, equipment and materials are to be furnished "in the box" new (unless specified as salvaged for reuse) and installed in strict accordance with the manufacturer's instructions. All products, equipment and materials are to be set in place, leveled and hooked up complete with all parts and in smooth and proper working order and ready to use. Materials, products or equipment that are damaged or defective in operation or appearance shall be replaced. All hardware and items with moving parts shall open, latch, lock and operate smoothly. All mounted items (including cabinets, handrails, towel bars, etc.) shall be attached to solid wood blocking. Contractor shall furnish material safety data sheets for all materials used.

OWNER'S SELECTIONS: Submit samples and manufacturer's literature in a timely manner as necessary for the Owner to select all products and materials with a choice of models, colors, styles, patterns, etc.

APPROVED EQUALS: Substitutions or approved equals are permitted only by prior written approval of Owner. Requests shall be accompanied by samples and documentation as necessary for comparison. Use of products, equipment and materials, colors or sizes other than specified, if not pre-approved, shall be cause for replacement at Contractor's expense.

PRODUCT INFORMATION: All manufacturer's printed product and equipment information, including warranties and owner's manuals, shall be saved in good condition and submitted in an organized fashion to the Developer at the end of construction in which to provide to the new homeowner.

RADON TESTING: Radon testing will take place after the house has been closed in. Coordinate with 3rd party testing company for the timing of the test. (General Contractor is not responsible for the cost of the radon test.)

GENERAL CLEAN-UP: The house interior and all yards shall be periodically cleaned up of construction debris to maintain a safe and orderly work site. The public sidewalk and boulevard and public alley shall be cleaned daily. No materials are to be dropped or stored on the boulevard or public sidewalk. The General Contractor shall be responsible for the collection, storage, removal from the site and recycling or disposal of all packaging, construction waste, debris and refuse.

CONSTRUCTION WASTE MANAGEMENT PLAN: Total construction waste to landfill or incinerator <2.5 lbs/SF of building.

Recycling and Recovery of the following Waste Materials:

2" Minus Material: Dirt, sheetrock dust, wood shavings, glass cuttings, asphalt shingle granules, small/broken aggregate, etc.

Aggregate: Concrete – precast or cast-in-place concrete, block, asphalt, terrazzo, plaster, brick, clay tile, quarry tile and ceramic tile, marble, and stone, etc.

Asphalt Shingles: Asphalt shingles, bundle wrappers (paper or plastic), cardboard boxes, incidental cans and bottles, tar paper, roof vents, eave and valley tin, etc.

Metals: Metal scrap - Iron, steel, copper, brass, and aluminum from the following sources – Structural members, piping, fasteners, steel studs, siding, wiring, ductwork and sheet metal goods, etc.

"Dirty" Wood: Painted wood and trim, plywood, particle board, oriented strand board, Masonite, wood doors, wood cabinets and furniture, etc.

"Clean" Wood: Unpainted, untreated dimensional lumber, timber beams & engineered wood products, wood shipping pallets, crates, etc.

Fiber: Cardboard – clean, corrugated cardboard used for packaging. Paper – clean paper from packaging, etc.

All construction waste to be placed in commingled dumpsters and transported to an off-site recycling facility

Carpet and carpet base determined to be recyclable shall be separated on-site and placed in a separate dumpster for removal and recycling.

Non-Recyclable Material: Gypsum wallboard, resilient flooring, post-consumer plastics, etc.

FINAL CLEAN-UP: Leave house "maid clean" at the completion of the work, including all finished surfaces, plumbing and electrical fixtures, appliances, tile, floor coverings, counters and cabinets, and both sides of window glass. Remove any stains and paint splatters on flooring, cabinets and

glass. Remove all non-permanent labels. Protect all finish floor circulation paths with temporary clear poly runners. Properly dispose of or recycle all debris. Remove all tools and construction materials.

PUNCH LIST: The Owner punch list walk-through shall be conducted after the final clean-up. Items not in accordance with the Specifications and Plans shall be listed and corrected to the satisfaction of the Owner. Assume some additional clean-up after punch list items are corrected.

VOLUNTARY ALTERNATES: All bidders are required to submit proposals per the Specifications and Plans/Drawings. No prior approvals will be issued for alternate products, materials or methods. The Owner may, however, accept voluntary alternates for products, materials or methods believed to be of equal quality and performance, and which may be of lower cost or greater availability. Any voluntary alternate should be listed separately from the submitted bid and identified as "voluntary alternate". These voluntary alternates will be evaluated by the Owner and Architect post bid. Owner will determine acceptance.

FUNDING REQUIREMENTS:

Minneapolis Disadvantaged Business Program:

Participation of Minority-owned Business Enterprises (MBEs) and Women-owned Business Enterprises (WBEs) is required on all construction projects exceeding \$100,000. Goals are established based on the number of certified WBEs and MBEs available in this marketplace and the types of work included in the project. An updated list of available certified SUBP contractors can be found at www.mnucp.org (MN/UCP). SEE ATTACHMENT B FOR GOALS & ATTACHMENT D FOR DOCUMENTATION SUBMITTAL REQUIREMENTS.

HUD Section 3:

Section 3 of the Housing and Urban Development Act of 1968 (12 U.S.C. 1701u) (as amended), requires that economic opportunities generated by certain HUD financial assistance for housing (including Public and Indian Housing) and community development programs shall, to the greatest extent feasible, be given to low and very low-income persons, particularly those who are recipients of government assistance for housing and to businesses that provide economic opportunities for these persons. SEE ATTACHMENT B FOR GOALS

Davis Bacon & Prevailing Wage

There is no Davis Bacon or prevailing wage on this project.

INSURANCE REQUIREMENTS

Contractor will provide to the Owner and the Owner's lenders a copy of a Certificate of Insurance, including Workers' Compensation insurance. Contractor shall obtain insurance with limits at least equal to those specified below:

| TYPE OF INSURANCE | | LIMITS |
|---------------------------|-----------------|-------------|
| GENERAL LIABILITY | Each Occurrence | \$2,000,000 |
| Damage to Rented Premises | Each Occurrence | \$ 100,000 |
| Medical Expenses | Any One Person | \$ 5,000 |
| Personal & Adv. Injury | | \$1,000,000 |
| General Aggregate | | \$2,000,000 |
| Products – Comp/Op Agg | | \$1,000,000 |

| | | |
|---------------------------|-----------------------------|---------------------|
| AUTOMOBILE LIABILITY | Combined Single Limit | \$1,000,000 |
| Any Autos | | |
| EXCESS/UMBRELLA LIABILITY | Each Occurrence | \$1,000,000 |
| | Aggregate | \$1,000,000 |
| WORKERS' COMPENSATION | | WC Statutory Limits |
| and | Each Accident | \$100,000 |
| EMPLOYERS' LIABILITY | E.L.Disease – Each Employee | \$100,000 |
| | E.L.Disease – Policy Limit | \$500,000 |

The policies obtained and maintained to provide the specified insurance must provide that the required coverage and limits cannot be materially changed or canceled without at least 30 days prior written notice to the Owner. PRG, Inc. shall be named as an Additional Insured, on a primary and non-contributory basis, as their interest may appear. Workers Compensation includes waiver of subrogation in favor of Certificate Holder.

Before beginning any work under this contract, the Contractor will provide to the Owner an insurance certificate showing compliance with these insurance specifications. It is understood that failure to provide the required insurance certificate, the Owner reserves the right to withhold payments to the Contractor until a properly executed Certificate of Insurance is provided. Contractor will provide liability insurance and workman's compensation insurance coverage in full until completion of the building certificates of insurance must be provided as a condition of the contract award.

QUALITY REQUIREMENTS

MINNESOTA GREEN COMMUNITIES-

ALL ASPECTS OF THE PROJECT ARE REQUIRED TO COMPLY WITH THE GREEN COMMUNITIES CRITERIA PROMOTING ENERGY CONSERVATION, OPERATIONAL SAVINGS AND SUSTAINABLE BUILDING PRACTICES IN AFFORDABLE HOUSING DESIGN.

All interior materials shall be no/low -VOC. The following requirements and other requirements described in specifications must be strictly followed:

☑ All paints and primers must meet the Green Seal GS-11 Environmental Standard

<http://www.greenseal.org/certification/standards/paints.cfm>

☑ Adhesives must comply with Rule 1168 of the South Coast Air Quality Management District and meet Green Seal GS-36 Env. Standard - <http://www.aqmd.gov/rules/reg/reg11/r1168.pdf>

☑ All caulks and sealants, including floor finishes, must comply with regulation 8, rule 51, of the Bay Area Air Quality Management District <http://www.baaqmd.gov/dst/regulations/rg0851.pdf> and may not exceed 250 grams of VOC per liter of coating as thinned to the manufacturer's maximum recommendation, excluding the volume of any water, exempt compounds, or colorant added to the tint bases.

☑ All particleboard components shall meet ANSI A208.1 for formaldehyde emission limits or all exposed particleboard edges shall be sealed with a low-VOC sealant or have a factory applied low-VOC sealant prior to installation.

All MDF shall meet Formaldehyde emissions requirements of ANSI A208.2 or all exposed MDF edges shall be sealed with a low-VOC sealant or have a factory applied low-VOC sealant prior to installation.

All work shall be executed in a workmanlike manner in accordance with the plans and specifications.

Project Manager to be notified immediately by General Contractor or Sub-contractor should any discrepancy or other question arises pertaining to the working drawings and/or specifications. The General Contractor shall be held responsible for any errors, discrepancies or omissions which result from the General Contractor failure to notify the Architect and Project Manager before construction and/or fabrication of the work.

On-site verification of all dimensions and conditions shall be the responsibility of the General Contractor and Sub-contractors. Noted dimensions take precedence over scale. The General Contractor and Sub-contractors shall report to the Owner all conditions which prevent the proper execution of their work.

The General Contractor agrees to a warranty period in accordance with state statute. In regards to the manufacturing warranty on individual equipment, the manufacturer's warranty will apply to all materials and equipment incorporated in the building. Warranties shall begin with the issuance of the Certificate of Occupancy.

The General Contractor will identify all subcontractors and suppliers contributing work and materials totaling more than \$1000 and provide the Owner a list of such subcontractors and suppliers in the form of a sworn construction statement – Attachment D. Sub-contractors shall: insure that all work is done in a professional workmanlike manner by skilled mechanics and shall replace any materials or items damaged by Sub-contractor's performance. Sub-Contractors and suppliers are hereby notified that they are to confer and cooperate fully with each other during the course of construction to determine the exact extent and overlap of each other's work and to successfully complete the work.

Each Sub-contractor, unless specifically exempted by the terms of his/her sub-contract agreement, shall be responsible for cleaning up and removing from the job site all trash and debris not left by other Sub-contractors. General Contractor will determine how soon after Subcontractor completes each phase of his work that trash and debris must be removed from the site.

SPECIAL INSPECTIONS / TESTING

Energy Rater (Building Knowledge Inc.) to complete initial, interim and final testing upon completion of project and issuance of Certificate of Occupancy. A blower door test may be conducted after installation of insulation and vapor barriers. The test should be used to find and fix leaks prior to installation of drywall. A final blower door test shall be conducted once the house is complete. Address all deficiencies identified by the Energy Rater.

PEST CONTROL

Seal all wall, floor, and joint penetrations with low-VOC caulking or other appropriate non-toxic sealing methods to prevent pest entry. Provide rodent- and corrosion-proof screens (e.g., copper or stainless steel mesh or rigid metal cloth) for openings greater than ¼ inch.

DIVISION 2 – SITE WORK

2300 EXCAVATION / BACKFILL / GRADING / EROSION CONTROL

It is the responsibility of the General Contractor to contact the survey company of record to request the site be staked for excavation. **Cost of staking the site for excavation is the responsibility of the General Contractor. Contact Kemper & Associates Inc. to have the site staked. Phone 651-631-0351 or kemper@pro-ns.net**

Excavate to depths as required for construction as shown on drawings. Footings to rest on undisturbed soil, fill any excess cut with concrete. The excavation shall be large enough to permit inspection of footings after the foundation has been completed.

Do not include pricing for soil corrections or excavation shoring in bid/construction contract. If either is necessary upon receipt of soils report or determined during excavation, they will be handled via post-bid addendum or change order.

A Soil Engineer must inspect the hole and approve the soil before foundation footings are installed. The General Contractor must provide the Owner with a copy of the Engineer's report. The General Contractor shall investigate sub-surface conditions, before and during grading of site, for filled excavations or buried structures such as cesspools, cisterns, and existing foundations. If any such structures are found and sub-surface conditions vary from plans or specifications, a soils engineer and structural engineer shall be consulted immediately, prior to the placing of any foundations.

All water shall be removed from foundation excavation prior to placing concrete. Backfill shall be clean, on-site soil, placed in 18" layers and compacted.

All topsoil and organic material shall be removed from within the building area. Any fill shall be granular inorganic fill placed in maximum 8" lifts and compacted to 92% standard density ASTM-D-698.

It shall be the Contractor's responsibility to get the excavations and fills thoroughly checked by a competent Soils Engineer prior to the placement of footings to prevent detrimental differential settlement. Variations to the above shall be at the discretion of the Soils Engineer.

Final grade as shown on elevations, is to slope away from structure 5% (3" per 5'-0") for 10' out from the foundation. Beyond 10' away from the building, the grade shall slope away from the structure at 1/4" per 1'-0" unless noted otherwise on plans.

Provide 6" min. topsoil at areas of excavation.

EROSION CONTROLS

Implement best practices for erosion and sedimentation control during construction. Install silt fencing and other measures as required by the City of Minneapolis.

Areas under porches or decks shall be covered in poly and landscape rock and fully enclosed with ventilated skirting detailed in the plans.

SITE DEMOLITION

Remove any volunteer growth, shrubs or trees not identified on site plan to remain. It is the responsibility of the General Contractor to do their due diligence and visit the site as part of the bidding process and determine which trees/growth needs to be removed per site plan in order to excavate the site properly and frame the structure. General Contractor is responsible for the cost of any tree/growth removal as part of the excavation or framing/construction process. General Contractor to seek approval from Project Manager before removing any trees/growth not shown per site plan.

2400 DRIVEWAY BITUMINOUS

~~DRIVEWAY: Install new bituminous driveway per site plan—3” rolled bituminous hot mix asphalt (MnDOT 2341) installed over new class 5 base, compacted to a minimum of 4”; assure proper slope for drainage away from overhead garage door. See 3200 Concrete Flatwork for concrete driveway.~~

2450 LANDSCAPING

The Contractor is responsible for providing temporary erosion control measures during the construction process.

Landscaping Plan - Install black plastic edging and landscape fabric 3' out around the entire perimeter of the house and around sides of garage. Install dark brown cedar mulch in this space (NO RED MULCH). Install new rolled sod over entire yard and as necessary to ensure no bare soil. Install new sod over new topsoil - clean black dirt thoroughly compacted to minimize settling before installing sod. Water new sod until grass is firmly established (minimum of 30 days). Replace any dead sections of sod until date of final certification by Developer or 30 days after issuance of Certificate of Occupancy by City of Minneapolis. No plantings – shrubs or flowers – to be provided. Use of any fertilizers or pre-emergents on lawn to be organic and non-toxic.

2500 WATER & SEWER SERVICE

Contact and/or subcontractor to provide and install new sewer and new copper water service per plans and per code. **Water Meter to be located in Utility/Mech area (see plan for specific location). Locating water meter in future Family Room area is not acceptable.**

DIVISION 3 – CONCRETE - FOUNDATION & FLATWORK

1. All reinforced concrete work shall be done in accordance with the “Building Code Requirements for Reinforced Concrete,” ACI 318, latest edition, and the “Specifications for Structural Concrete for Buildings,” ACI 301, latest edition. All strengths noted below are 28-day strengths.

a. Interior slabs on grade: 3000psi

Water/Cement Ratio (by weight): .5

Slump: 4”

b. Footings: 3,000psi

c. All other poured in place structural concrete: 4,000 psi

d. Exterior concrete shall have 5% minimum entrained air.

2. Provide necessary insulating blankets to ensure concrete cures when temperatures indicate a barrier is needed.

REINFORCING STEEL

Reinforcing steel shall conform to ASTM A-615, Grade 60.

Welded Wire Mesh shall conform to the latest revised ASTM A-185. Smooth wire fabric shall conform to ASTM A-85, yield strength 60 KSI.

All bars in concrete shall be lapped a minimum of 36 bar diams. (2'-0" min.) at all splices unless noted otherwise.

Splices of horizontal rebar in walls and footings shall be staggered 4'-0" minimum.

Dowels for walls and columns shall be the same size and spacing as the wall/column reinforcing unless noted otherwise.

All bending of reinforcing steel shall conform to the latest adopted edition of the International Residential Code.

3100 FOUNDATION

Provide and install footings and foundation walls and slab for the house and porches.

Foundation (widths and depths) and reinforcing as shown on plans are superseded by any local codes or ordinances, which require increases of the same.

Install Delta Footing Barrier (or equal) as a capillary break between the footings and foundation walls.

1. All footing elevations shown are to top of footings.
2. All footings to be centered under walls or columns above, unless noted otherwise.
3. Provide 3" clear cover for all footing reinforcement. Footing rebar shall be #5 continuous. Foundation wall reinforcement shall be #5 rebar at 24" o.c. Each way with dowels to match. Add one #4 bar continuous at the top of the wall.
4. Provide wall footing reinforcing in stock lengths and bend in field as required. Lap bars minimum 42" diameters and stagger splices.
5. Cast dowels in footings to match bars above where reinforced walls or columns occur. Column and wall reinforcing dowels to project 30 bar diameters above top of footing unless noted otherwise. Provide 90-degree bend in footing dowels and straight dowels in wall footings, unless noted otherwise.
6. Sill Fastening: Exterior non-bearing and exterior bearing walls." diameter x 10" anchor bolts with 2" diameter washers, 7" into concrete, spaced at 6'-0" maximum, plus 12" from corners and splices unless otherwise noted on plans.
7. Shore all walls adequately before backfilling and compacting.
8. Wall footings shall be stepped 1 vertical to 2 horizontal at elevation changes unless noted otherwise.
9. No part of the structure shall be placed on frozen soil or foundation. If the building will be under construction during freezing weather, all interior footings shall be depressed 3'-6" below construction grade or insulated for frost protection.

Pipes may pass through structural concrete in sleeves, but shall not be embedded therein. Pipes or ducts exceeding one-third the slab or wall thickness shall not be placed in the structural concrete unless specifically detailed.

Do not place concrete until all reinforcement, conduit, outlet boxes, anchors, sleeves, bolts, or other embedded materials and items are securely and properly fastened in their proper places and position. Sub-contractor shall verify installation of anchor bolts, straps and other anchorage material and items prior to placement of concrete.

Basement floor to be a minimum 3.5" thick and reinforced with welded wire fabric (WWF) with a smooth, steel trowel finish. Minimum 6-8" base of 3/4" stone aggregate covered by 2" XPS rigid insulation and 6 mil vapor barrier. Lap joints in vapor barrier 12" minimum.

3130 FOUNDATION DRAINAGE

Provide an exterior and interior perimeter drain tile system consisting of a 4" plastic drain tile sloped to and terminating in a collection sump basket with sump pump.

Surround pipe in gravel and wrap gravel in filter fabric.

Install a plastic sump cover designed specifically for sealing a Radon vent to the sump hole. The cover must be bolted down. Provide an outlet and install sump pump. Install piping to discharge sump to daylight per location shown on site plan. Include backwater/check valve.

Sump Basin to be PlumbStar USA 18" x 22" Sump Basin (model # PSU1011) with sump cover,

The Original Radon – Sump Dome also by Plumbstar USA (model # PSU1015).

3140 RADON-CONTROL

Provide a sub-slab vent for the Radon Gas by 8" of 3/4-inch stone. Grade and tamp soil to provide solid base. Install the 3/4" stone and install a 6" PVC Tee connected to a 4" PVC pipe in the stone base vented above the roof line to a Schedule 20 PVC varmint guard cap and flashed to the roof with a metal based neoprene boot. The vent should be installed a minimum of 12" above the roof and a minimum of 10' away from any window or other opening that could bring the exhausted radon gases into the residence. Install a continuous 6 mill plastic vapor barrier between the stone and the concrete sealed carefully to the vent pipe. Pour a 4", 3000 psi concrete slab. Float and steel trowel finish. Seal all cracks and control joints with a low VOC polyurethane caulk.

Install an Energy Star rated radon fan in the attic per plan wired directly to the electrical panel from a junction box installed within 6' of the fan. Use rubber boots to connect the fan to the 4" vent, RadonAway RP140C or approved equal. Provide and install a manometer for ongoing monitoring of system functionality.

3150 FOUNDATION WATERPROOFING

Provide and install Tuff-N-Dri liquid applied waterproofing with Warm-n-Dri R-15 rated foundation/insulation board or R-15 rated XPS rigid insulation board on the exterior of the concrete foundation walls. Tuff-N-Dri waterproofing needs to be adequately cured before applying foundation/insulation board.

3200 CONCRETE FLATWORK

Provide and install new basement slab/floor. Basement floor to be a minimum 3.5" thick and reinforced with welded wire fabric (WWF) with a smooth, steel trowel finish. **Minimum 6-8" base of 3/4" stone covered by 2" XPS rigid insulation.** Tape joints in rigid insulation prior to pouring basement slab.

Provide and install new garage slab/floor. Floor to be a minimum of three and one-half (3.5) inches thick with thickened edges and reinforced with welded wire fabric (WWF).

Provide and install new driveway, minimum 4" thickness, 4000 PSI. Install on sound subsoil with Class 5 base material as needed for proper uniformity and drainage. Use clean sound aggregates. Light broom finish. Grade driveway area shall be compacted before installed. Assure proper slope for drainage away from overhead garage door.

Provide and install new walks. Walks from public sidewalk to front porch/stoop, walk from garage to rear entry and carriage walk shall be 4'-0" wide. Both front and rear walks shall have 4" thick concrete with 6x6 10/10 WWF and a 6" layer of class 5 base material. Light broom finish. Grade under sidewalk areas shall be compacted before walks are installed.

For all Concrete Flatwork detail see plans and site plan.

General Contractor is responsible for inspecting/documenting the condition of the public sidewalk at the time of bidding and commencement of construction and for replacing all sections of public sidewalk that have or are damaged during construction or removed to provide utility access.

DIVISION 4 – MASONRY

4200 – MASONRY BLOCK

Provide and install a minimum of one course of 6" CMU at the perimeter of the garage slab.
Provide anchor bolts at 6'-0" o.c. Maximum.

DIVISION 5 – METALS

Bolts, nuts, and screws shall conform to ASTM A-307 Grade "A".
Structural steel shall be ASTM A-36 unless noted otherwise. Tube steel shall be ASTM A-500 Grade B (Fy=46ksi) unless noted otherwise.

DIVISION 6 – CARPENTRY / FRAMING

6100 ROUGH CARPENTRY - FRAMING

1. Studs, joists, rafters, foundation plates, or sill, planking 2 inches or more in depth, beams, stringers, posts, structural sheathing and similar load-bearing members shall be of at least the minimum grades set forth in the International Residential Code, current applicable edition.

2. Sizes noted and referenced are nominal sizes. See plans for net size when specified.
All lumber to be kiln dried, free from imperfections which might impair its strength or durability.
All composite wood products including plywood and OSB shall meet Formaldehyde emissions requirements of ANSI/HPVA HP-1-2016 & California standard 93120 for low-VOC content. If not compliant with California 93120 must have all exposed edges sealed with low-VOC sealant.

Sub Floor: OSB, formaldehyde-free, glued and nailed per drawings, except at floors to receive ceramic tile which shall have plywood as the subfloor.

Wall Sheathing: 15/32" OSB unless noted otherwise or approved.

House Wrap: Tyvek, Typar or equal

Roof Sheathing: ½" CDX plywood

Studs: 2"x 4" construction grade 16" o.c. at interior unless noted otherwise 2"x 6" construction grade 16" o.c. at exterior.

Supporting bearing partitions: Bearing partitions perpendicular to joists shall not be offset from the supporting girders, walls or partitions more than the joist depth. Joists under and parallels to bearing partitions shall be doubled.

Underlayment: Provide per recommendations of finish flooring material manufacturer.

Floor and Roof Trusses: Provide all trusses and structural elements required to structure the roof and floors as indicated in the drawings. Truss shop drawings to be provided to Architect and Owner for review. Shop drawings shall include a plan layout plus detailed truss drawings. Note: trusses to be designed to support future solar panels.

a. Manufacturer shall supply to the Architect, Owner and the Building Department calculations and shop drawings for approval of design loads, prior to fabrication. A Professional Engineer registered in the State of Minnesota shall sign all calculations and shop drawings. It shall be the responsibility of the manufacturer to obtain Building Department approval of calculations and shop drawings prior to fabrication.

b. All connectors shall be ICBO approved and of adequate strength to resist stresses due to the loadings involved.

c. Cross bridging and/or bracing shall be provided and detailed as required to adequately brace all trusses. Bridging, headers, corner bracing, nailing, blocking, furring to be according to standard building practices, local codes and ordinances.

d. High roof trusses shall be designed for 40 psf snow load (which may be reduced for slope) plus dead loads. Low trusses (garage and porch) shall be designed for 40 psf snow load (with increases according to Minnesota Building Code Section 1365.0600) plus dead load.

STRUCTURAL NOTES & GENERAL NOTES

Structural members including slabs, beams, trusses, columns, and walls are designed for “inplace” loads. Contractor is responsible for bracing, without overstressing, all structural elements as required at any stage until completion of this project. All construction shall be done in accordance with the “International Residential Code” Current Edition, unless noted otherwise.

Contractor shall verify all dimensions and conditions on site before construction is begun. All observed discrepancies shall be reported immediately to the Architect.

Design Loads:

Roof Live load 40 psf

Floor Live load 40 psf

Partition 10 psf

Deflection Criteria L/480

COLUMNS AND POSTS

Columns and posts located on concrete floors or decks exposed to the weather or to water splash or in basements and which support permanent structures shall be supported by concrete piers or metal pedestals projecting above floor unless approved wood of natural resistance to decay or treated wood is used. The pedestals shall project at least 6 inches above exposed earth and at least 1 inch above such floors.

PLATES, SILLS, AND SLEEPERS

All foundation plates or sills and sleepers on a concrete slab, which is in direct contact with earth, and sills which rest on concrete foundations, shall be pressure treated wood all marked or branded by an approved agency. Wood Ledgers (Sill Plates): Pressure treated wood properly anchored and sill sealed. Wood embedded in the ground or in direct contact with the earth and used for the support of permanent structures shall be treated wood. Wood joists or the bottom of wood floors closer than 18 inches, or wood girders closer than inches to the ground under-floor areas and their supports, shall be treated wood or all heartwood of approved naturally durable species as listed in the IRC, applicable edition.

DIVISION 7 – THERMAL & MOISTURE PROTECTION

7300 ROOFING

Shingles: 240#, fiberglass-based asphalt shingle, GAF Timberline, Certainteed Landmark, Owens Corning Duration, dimensional/architectural look shingle, or approved equal.

Ice and Dam Shield: Waterguard Ice Barrier or equal. Provide to 2'-0" back from interior face of exterior wall. Provide at each side of valleys. Also provide at roof to wall connections on vertical wall surface to 2'-0" above line of roofing under flashing. Fasten roofing materials with roofing nails – use no staples.

FLASHING

Flashing and counter flashing. Exterior openings exposed to the weather shall be flashed in such a manner as to make them weatherproof. Flashing and counter flashing shall be provided at the junction of the roof and vertical surfaces (walls, etc.). All flashing, counter flashing and coping,

when of metal, shall be of not less than No. 18 U.S. gauge corrosion-resistant metal. Valleys must be metal, inverted "V" Type, 26 gauge. Roof valley flashing shall be provided for shingles as follows: Flash and counter flash at all roof to wall conditions. (Use Waterguard Ice Barrier or equal up side of wall 2'-0" at this condition.) Where exposed to weather, flash all horizontal wood trim butting to exterior finish.

ATTIC VENTILATION – next page-

Roof and Soffit Venting: Continuous soffit venting, ridge vents to be Shingle Vent II by AirVent, Inc. and additional roof vents as necessary to meet code requirements. Coordinate location of any required additional vents with Project Manager.

7640 EXTERIOR SIDING / TRIM / SOFFIT / FASCIA

Exterior Siding and related trim and accessories: LP Smart Side, pre-finished engineered lap siding, shakes, board and batten and trim. See plans/drawings for siding/trim/accessories sizing/dimensions and location. Note: Lap siding to be 8" cedar wood grain finish (6-7/8" reveal). Trim to be textured finish. LP Smartside shingles/shakes, panels and trim boards to be prefinished, LP Diamond Kote or LP ExpertFinish. Developer to provide color selections. Siding and trim to be installed per manufacturer's instructions/specifications and per the plans. **Shakes/shingles on Craftsman plan to be installed straight-edge not staggered. Board and batten on Folk plan to be 7/16" thick textured LP Panel with 1"x3" textured LP Trim.** Soffit and Fascia to be aluminum, manufactured by Rollex, Alcoa or approved equal. Minimum .024 gauge. Project Manager to select color. Provide Tyvek or equivalent high-performance house wrap and install per manufacturer's instructions.

7650 GUTTERS AND DOWNSPOUTS

Provide 5" box type, .032 painted seamless aluminum gutters, 3"x4" downspouts and extensions. Provide 12"x13" concrete splash blocks. Gutters must be installed at roof and porch. No gutter shall empty directly onto another roof surface. All downspouts must empty at grade. Downspouts to be located at all four corners of the house.

7660 INSULATION & AIR SEALING

Walls: R-20- batts at all 2x6 exterior walls with 1" R-5 rigid insulation over exterior sheathing and under siding.

Cantilever: Insulate to R-30 with batt insulation.

Rim joists: 3" of closed-cell sprayed polyurethane foam. (to R-21)

Attic/Ceilings: Attic insulation to be R-60 plus blown fiberglass with 6 mil poly vapor barrier.

Foundation –insulate to R-15 – Exterior – 3" XPS rigid insulation with R-15 rating and/or R-15 rated (3-1/2") Warm-N-Dri foundation board. Refer to plans for detail.

Basement slab – install 2" of XPS rigid foam board (with R-10 rating) insulation under concrete basement slab.

Install batt insulation on all interior bathroom walls as sound insulator.

Seal all accessible cracks, gaps and holes in the building envelope (the barrier between the indoor conditioned space and the outside) with low VOC caulk (if <1/4") or expanding foam (if > 1/4"). Seal all top plate and bottom plate penetrations. If the foundation masonry wall is open core concrete block seal the tops of the block with expanding foam. Seal all penetrations created by plumbing, gas lines, electrical boxes and outlets. Seal large accessible gaps around windows between house framing and window frame, do not use high expansive foam on these. Take care to seal all joints without excess sealant. Seal any gaps in the building envelope adjacent to flues with carefully cut to fit sheet metal that is securely fastened to framing sealing all seams and gaps with fire rated caulk.

Seal recessed light fixtures in ceilings that are part of the building envelope and are not rated for insulation contact with an airtight box made of drywall sealed to the ceiling and seal IC rated recessed fixtures with caulk. Seal any entries to attic space using weather stripping on attic doors or hatches. Air sealing must be done prior to the installation of insulation. Provide rodent and corrosion-proof screens for openings greater than .25 inches.

VAPOR BARRIER -

Install vapor barriers on the warm side of all walls and 2nd floor ceilings as shown on Drawings. Vapor barriers to be 6 mil polyethylene. All rips or improperly sealed joints shall be repaired prior to installation of gypsum sheathing.

DIVISION 8 – DOORS AND WINDOWS

8200 DOORS – EXTERIOR & INTERIOR

Exterior Doors to be Energy Star rated with .25 U-Value or less and .25 SHGC

Front entry door shall be 36 in. x 80 in. less than 1/2 Lite Fiberglass Prehung Front Door , **Energy Star qualified with .25 U-Value or less and .25 SHGC** or approved equal. Paint to finish. Developer to select color.

- Rear entry door shall be 36 in. x 80 in. Blinds between glass 1/2 Lite Fiberglass Prehung Door, **Energy Star qualified with .25 U-Value or less and .25 SHGC**, or approved equal. Paint to finish.
- Garage service door shall be flush metal - bored for deadbolt lock. Paint to finish.
- Storm door at front entry Andersen 3000 Series Self-Storing Storm Door full view and back entry: Larsen midview aluminum storm door. Developer to select finish color.
- 16'x7' Overhead Garage door shall be pre-finished paneled 24-gauge steel door and ½ horsepower power chain drive overhead door operation and all track and hardware required. Midland Valucraft Plus or equal. Color to be determined by Project Manager.

INTERIOR DOORS

Interior doors shall be 34" Masonite solid core 2-Panel, square, or approved equal, Project Manager to approve. See plans for sizes and swings.

DOOR HARDWARE/MISC

- Exterior and Interior door hardware to be Kwikset Juno, oil rubbed bronze or approved equal.
- Equip front and rear door with deadbolts and deadlocking latches.
- Deadbolts shall contain hardened inserts or equivalent.
- Locksets to be single cylinder 1-1/2" throw tumbler dead bolts in addition to key in knob entrance locks (keyed alike). Provide solid backing at latch area of entry doors.
- Overhead and sectional garage doors shall be secured with a cylinder lock, pad with a hardened steel shackle, metal side bar bolt or equivalent when not otherwise locked by electrical power operation.
- All entry doors to be weather-stripped.
- Sills to be of width to provide full seal for bottom of storm door.
- All interior and exterior doors shall have three hinges – oil rubbed bronze finish.

8500 WINDOWS

All windows to have a U-Factor/Value of .25 or less with SHGC of any rating. Install Andersen 100 Series – Low-E Smart Sun w/ HeatLock with Argon, U-Value of .25 or less with SHGC of any.

See window schedule. Tempered glass shall be used where identified/required by law/code. Obscure glass to be used in bathrooms in U-factor and SHGC can be met. Interior finish color to be white. Project Manager to select exterior finish color and approve window Finelight grille pattern. Approximate rough openings are noted on plan. Submit shop drawings with rough openings on all windows to General Contractor. All windows must have locks and lifts. Interior jambs to be painted to match interior trim. Install screens at all windows, including all basement windows. All storm/screen units must be made of fiberglass screen cloth. Provide window grids per plans. Provide and install 1” vinyl or metal mini-blinds at all windows, interior mount.

DIVISION 9 – FINISHES

ROOM FINISH SCHEDULE

| ROOM | FLOOR | BASE | TRIM | WALLS | CLG’S |
|------------------------------|----------|---------|---------|---------|------------|
| Rear Entry | LVP | Painted | Painted | Painted | Smooth |
| Powder (1/2 Bath) | LVP | Painted | Painted | Painted | Smooth |
| Front Entry | LVP | Painted | Painted | Painted | Smooth |
| Hall-1 st Floor | LVP | Painted | Painted | Painted | Smooth |
| Living Room | LVP | Painted | Painted | Painted | Smooth |
| Dining | LVP | Painted | Painted | Painted | Smooth |
| Kitchen | LVP | Painted | Painted | Painted | Smooth |
| Bedrooms | Carpet | Painted | Painted | Painted | Knockdown |
| Hall – 2 nd floor | Carpet | Painted | Painted | Painted | Knockdown |
| Loft/Stairs | Carpet | Painted | Painted | Painted | Knockdown |
| Bath-Upper | TILE | TILE | Painted | Painted | Knockdown |
| Basement | Concrete | N/A | N/A | | taped rock |

Closet finish to match room in which it is located.

9200 DRYWALL & BACKERBOARD

ALL GYPSUM WALLBOARD TO BE COMPOSED OF AT LEAST 25% POST-CONSUMER RECYCLED CONTENT OR AT LEAST 50% POST-INDUSTRIAL RECYCLED CONTENT.

Gypsum board – Interior walls shall be 1/2” drywall taped and sanded. Interior ceilings shall be 5/8” drywall taped and finished per finish schedule. All gypsum wallboard shall be installed in accordance with the provisions of the applicable codes. **All drywall in bathrooms to be paper-less drywall – Georgia Pacific DensArmor Plus, or approved equal.**

Provide all metal trim, nails, screws, tapes, compound and adhesive. Provide protective edges at exposed gypsum board edges, especially at basement stair.

Gypsum wallboard shall not be installed until weather protection for installation is provided. All edges and ends of gypsum wallboard shall occur on the framing, members, except those edges and ends which are perpendicular to the framing members. All edges and ends of gypsum wallboard shall be in moderate contact except in concealed spaces where fire resistive construction or diaphragm action is not required.

The size and spacing of fasteners shall comply with code. Fasteners shall be spaced not less than 3/8-inch from edges and ends of gypsum wallboard. Fasteners at the top and bottom

plates of vertical assemblies, or the edges and ends of horizontal assemblies, or the edges and ends of horizontal assembly's perpendicular to support, and at the wall line may be omitted except on fire-resistive assemblies. Fastener's shall be applied in such a manner as not to fracture the face paper with the fastener head.

BACKER BOARD

Install 1/2" fiberglass reinforced cement composition boards such as DurockR or HardieBacker™ in areas specified to accept ceramic tile. Space edges 1/4" from adjoining surfaces and fasten with minimum 1-1/4" long No. 8 x 0.375" HD self-drilling corrosion-resistant ribbed wafer-head screws (i.e. High-Low Rock On screws) designed specifically for backer board. Use product specified by manufacturer for particular application (such as walls or floors). For floors bond backer board to plywood subfloor with thin set mortar using a 1/4' square notched trowel. On walls, all edges of backer boards must be supported by full face 2' framing secured to the structure. On floors, backer board must be installed on 3/4' plywood over joists 16" on center or the joist/subfloor assembly must meet the manufacturer's specifications.

9300 PAINTING – EXTERIOR & INTERIOR

Delivery, Storage, and Handling to conform to applicable code for flame/fuel/smoke rating requirements for finishes. Hirshfield's, Sherwin Williams or approved equal—note requirement on VOC's. All paints to meet Green Seal Standard GS-11.

EXTERIOR

Prime and paint or stain all exposed surfaces including all siding, trim, porch posts, rails, spindles, decking and skirting.

Apply all finish coats as soon as possible or within 180 days of installation.

Siding and Trim - Apply two coats of high-quality acrylic latex paint, Sherwin Williams or Hirshfield's SELECT 1000 – Professional 100% Acrylic Exterior Coating.

Follow the coating manufacturer's application and maintenance instructions.

Re-prime factory primed hardboard where needed with Hirshfield's #4250 Acrylic Primer.

Unprimed factory hardboard also requires 1 coat of #4250 Acrylic Primer.

Cedar decking components – Apply 2 coats of Cabot Wood Toned Deck and Siding Stain or approved equal. Project Manager to select finish and color.

INTERIOR

PRIMER: Sherwin Williams or Hirshfield's Contractor Select Hi-Build Primer or Owner approved substitute.

PAINTS: Walls to be painted with Sherwin Williams or Hirshfield's Contractor Select High Hide low odor low VOC interior flat finish paint or Owner approved substitutes. Doors and trim/millwork to be painted with Satin finish paint, Sherwin Williams Hirshfield's Platinum Ceramic interior satin latex enamel paint or approved substitute. Submit two samples to Owner of 2"x 2" in size of paint samples for both interior and exterior selections for approval. **Interior Paint VOC levels not to exceed 50 g/l (grams/liter) for flats and non-flats, 100 g/l for floors and 250 g/l for any anti-corrosive paints used.** No spray texture in kitchen or baths.

Deliver products to site in scaled and labeled containers; inspect to verify acceptance.

Container labeling to include manufacturer's name, type of paint, brand name, brand code, VOC level, coverage, surface preparation, drying time, clean-up color designation, and instructions for mixing and reducing. Store paint materials at minimum ambient temperature of 45 degrees F and a maximum of 90 degrees F, in well ventilated area, unless required otherwise by manufacturer's instructions. Take precautionary measures to prevent fire hazards and spontaneous combustion.

Extra Stock

Provide a one-gallon container of each color to owner. Leave in basement. Label each container with color, texture, locations of usage, in addition to the manufacturer's label.

Inspection

Verify that all surfaces are ready to receive work as instructed by the product manufacturer. Examine surfaces scheduled to be finished prior to commencement of work. Report any condition that may potentially affect proper application. Beginning of installation means acceptance of existing surfaces.

Preparation

Remove electrical plates, hardware, light fixture trim, and fittings prior to preparing surfaces of finishing. "Bagging" will not be accepted. Correct minor defects and clean surfaces which affect painting work.

Protect elements surrounding the work to be painted from damage or disfiguration. Repair damage to other surfaces caused by work of this section. Furnish drop cloths, shields, and protective methods to prevent spray or droppings from disfiguring other surfaces. Remove empty paint containers from site.

CEILINGS & WALLS: Apply products in accordance with manufacturer's instructions. Do not apply finishes to surfaces that are not dry. Apply each coat to uniform finish. Prime back and field cut surfaces of interior and exterior woodwork with primer paint. Gypsum wallboard to receive one coat of primer, and two coats of latex, up to 3 colors to be selected. Walls under sinks must be painted. All woodwork to be painted, – color to be determined by owner. Interior surfaces of closet doors shall be finished the same as the outer side. Closets must be painted.

Tape and paint basement stairwell walls, and paint treads, stringers, and risers.

9400 WOODWORK / FINISH CARPENTRY

INTERIOR

Trim: Install new paint-grade millwork, square edge style throughout the house, baseboards 1x6 with ¾" shoe and door & window casings 5-1/2" Header trim and 3-1/2" side casing. Note: First floor Powder (½ bath) to have wood base/trim to match rest of first floor. (upper bath to have ceramic tile base). See plans for typical door and window trim.

Railings: Paint grade wood, color to be selected by Project Manager.

Posts & Balusters: Paint grade square balusters and box newel painted to match rail.

EXTERIOR

See plans for exterior column, post, rail, baluster and skirting detail.

ATTIC ACCESS

Install picture frame trim around attic access with a minimum size of 22"x30".

Attic access must be openable to check insulation at final inspection.

9600 FLOORING – TILE / LUXURY VINYL PLANK (LVP)/ CARPET

TILE

Daltile 12 x 24 Porcelain Tile Nova Falls Gray – Model # NP101224HD1P6 SKU # 1002820802 available @ Home Depot or approved equal. Grout color: light gray to match tile color. Ceramic to have a screwed and glued cement board underlayment as per manufacture recommendations. Tile flooring to have ceramic tile base.

LVP- Luxury Vinyl Plank

LVP to be EJ Welch – Style: Rigid Core, Color: #6009-3, 48"x9" wide planks, minimum 15 yr. warranty, SCS FloorScore certified, or approved equal. Underlayment for LVP flooring: FloorMuffler UltraSeal underlayment or approved equal.

CARPETING

Carpeting and pad to be Carpet & Rug Institute (CRI) Green Label Plus certified: EJ Welch, Style: Better Plus, Color: #641 Smooth Sail or TrafficMaster – Thoroughbred II Color: Chestnut – Model # EF286-1858 SKU # 763022 @ Home Depot. or approved equal.

Carpet pad to be 6 lb. min. density, 1/2" min. gauge recycled fiber or prime pad. Stretch carpet to eliminate puckers, scallops & ripples. Cover entire floor including closets using tackless strips to fasten carpet at walls and metal transition strips at transitions to other floor surfaces.

DIVISION 10 – CABINETS / SPECIALTIES & ACCESSORIES

10100 CABINETS

Kitchen cabinets and bath vanities to be Mid Continent-Signature Series-Maple -Concord style door, painted finish or Armstrong Rutledge, maple, painted finish, or approved equal. Shaker style door (Flat panel square) with slab drawer front and laminate interiors. Finish paint color to be selected by Project manager. Contractor to provide and install cabinet door and drawer hardware (pulls) to be selected by Project Manager. Kitchen and bath cabinets to be certified under the Kitchen Cabinet Manufacturers Association's (KCMA) Environmental Stewardship Cert. Program.

10200 COUNTER TOPS & VANITY TOPS

Kitchen countertops to be granite or approved equal with 4" backsplash. Color/style to be selected by Project Manager. Vanity Tops to be cultured marble – solid white or same granite as kitchen countertop.

10300 BATHROOM ACCESSORIES

Toilet accessories shall be approved or selected by Project Manager.

2 towel bars at upper bath.

1 towel ring at upper bath.

1 robe hook at upper bath.

1 towel ring at first floor Powder Room (1/2 bath).

Toilet paper holder at each bath.

Mirrors: plate glass as noted on prints. Pencil edge, 36" high and full width of vanity top.

10400 CLOSET ACCESSORIES

Provide & install metal brackets, white melamine shelving and wood clothes rods per plans.

10500 POSTAL SPECIALTIES

Mailbox at main entry door with full size magazine capability to meet postal service requirements, finish/color to be selected by Project Manager.

House numbers at front of home and at garage facing alley to be metal and no less than 4" in size.

To be selected by Project Manager

TYPICAL MOUNTING HEIGHTS – FROM FLOOR

Shower head – to center of arm: 6'-4"

Shower curtain rod: 6'-6"

Towel bar/ring: 4'-0"

Closet Shelf & rod: 5'-2"

Electrical panel: 5'-0"

Electrical outlets: 12"
Electric outlets above counter: 6" above top of backsplash.
Light switch: 4'-0"
Thermostats: 5'-0" to top
Telephone jack: 12"
Wall telephone: 4'-6"
Heat supply registers in floor
Cold air returns: 8" to bottom of walls.

DIVISION 11 – EQUIPMENT - APPLIANCES

11100 RESIDENTIAL EQUIPMENT (APPLIANCES)

All refrigerators, dishwashers, clothes washers and clothes dryers to be Energy Star qualified. Furnish & install, appliances to be hooked up, leveled & ready to operate.

Refrigerator-Whirlpool WRS331SDHM 21 cu ft. refrigerator & ice-maker, Energy Star-rated; or approved equal

Dishwasher-Whirlpool – WDF520PDAM: 24" wide built-in, tall tub, 3 cycle, 4 option, Energy Star rated or approved equal

Gas Range-Whirlpool - WFG510S0AS: 30" wide free-standing, with pilotless electronic ignition, sealed burners, self- cleaning oven, anti-tip device and clock/timer, or app. equal.

Microwave/ Vent Hood Combination (venting to exterior)-Whirlpool - MH31017AS: 30" wide, 1.7 cu. ft., 1000-watt oven, 2-speed venting 170/300 cfm, or approved equal.

Washer – GE -GTW680BSJSW: Energy Star rated - top load, 3.8 cu. ft. 27.5" wide 27" deep, 43" high & PFWMH4PR 4' washer hoses, or approved equal.

Dryer-GE -GTD65GBSJWS: natural gas, Energy Star rated, front load 7.0 cu. ft. 29" wide, 27.75" deep, 43" high, or approved equal.

Dehumidifier - Provide and install an Energy Star "basement-rated" dehumidifier, with hose extension to floor drain in order to drain continuously.

DIVISION 15 - Mechanical & Plumbing`

15100 – HEATING / COOLING / VENTILATION

Building Performance Standard - **Project to follow under Energy Star New Homes Version 3.2 (Rev. 13) and be certified under DOE Zero Energy Ready Home (ZERH) Single Family Homes National Program Requirements Version 2.** Heating Contractor shall provide all necessary labor and material and perform all heating work of every nature whatsoever in the installation of heating plant of sufficient size to properly heat all finished parts of the house as per the requirements of the I.R.C. Forced Air System: Forced air heating shall in all cases shall conform to local ordinances. The heating plant shall be sized and selected as follows: Use the Air Conditioning Contractors of America (ACCA) 8th Edition of their Manual J Heat loss calculation tool <http://www.acca.org/tech/manual J/> (calculate manual J based on the new building envelope), and use ACCA's Manual S for equipment selection. NOTE: Provide both Manual J & S reports with initial Draw documents. Size furnace to the living unit considering any areas which may be added or subtracted from the plan.

Provide a central ducted cold air return and ensure easy access, good fit for easy replacement of air filter. **Install MERV 8 or better furnace air filter.** An exterior return air filter box shall be installed on one side, both sides, or bottom of new furnace. Seal all exposed duct joints as a part of this item with Duct Mastic.

General design, furnish and install forced air duct work to furnace to heat living areas and basement to min. of 68 degrees F. with outside temp –20 degrees F. Provide transfer ducts for balanced pressure between rooms: Tamarack Return Air Pathway (RAP) 12.6 (12" x 6") Sound and light restricted by-pass grill to air balance forced air system. Install in stud cavity between specified room and common space to provide return air. Seal to wall finish and install flange trim.

Heat loss/gain calculations shall be in accordance with the procedures contained in the American Society of Heating, Refrigeration and Air Conditioning Engineers (ASHRAE) "Handbook of Fundamentals" or other nationally recognized procedure.

Submit shop drawings to General Contractor for approval. Shop drawings shall include heat loss calculations, furnace data, grill and register data and duct layout.

The City of Minneapolis enforces the Administrative section of the Energy Code which prohibits the use of the permanent furnace during the construction period. If heat is required, provide and install a temporary unit(s). Protect all duct openings from debris during construction and vacuum out ducts prior to installing registers/grills. Verify furnace filter is 8 MERV or better, new and clean at time of final inspection.

HEATING: Upon completion of construction **(after all dust producing construction activities)**, install high-efficiency, dual stage, **96% AFUE** or greater, sealed combustion natural gas furnace with variable speed ECM motor: Goodman GMVC96 or approved equal on 2" concrete pad. New furnace to be vented with PVC piping per manufacturer's specifications. New furnace will have minimum limited warranties of: 20 years on heat exchangers; 5 years on parts. Include auto set back thermostat controls, vent pipe & new shut-off valve.

COOLING: Install 1.5 ton, minimum **14 SEER** or better air conditioner with AHRI matched evaporator coil – Goodman GSX or approved equal.

VENTILATION: Whole-house mechanical ventilation system efficiency 1.2cfm/W balanced with heat exchange, 65% ASRE.

ERV: Install Broan AI Series / Virtuo - B160E65RT (top ports)/B160E65RS (side ports) 150 CFM ERV. Install Broan wall control unit VAUTOW (VC0184) to be located adjacent to system.

BATHROOM FANS: Install **Energy Star** rated low sone ceiling mounted exhaust fans w/light, vented to the exterior. Upper floor bath 80 CFM minimum and ½ Bath 50 CFM Install rigid metal duct, vent to the exterior ideally through a wall/gable end using a 4" hooded vent with damper.

All duct seams shall be sealed with duct mastic. Insulate the ductwork with foil faced R 6 minimum duct insulation. Air seal fan/light assembly to the ceiling with low VOC caulk. Ventilation system must satisfy the fresh air requirements of ASHRAE 62.2-2010. **DRYER:** entire vent to be 4" rigid metal vent tubing from the specified dryer location, vented to the exterior, with a back-flow preventer and NO screening at DryerBox. **No flex ducting at dryer.** Do not fasten with nails, screws or other fasteners that protrude into the interior of the exhaust duct. Seal all seams in the system with duct mastic or aluminum foil tape (no duct tape) or clamps. Heating contractor to vent all bath fans, range hood fan and dryer vent.

Kitchen Range hood or OTR Microwave/Hood vented to outside, intermittent rate of 100 CFM.

Ventilate the home with outside air at the highest rate and duration practical during the period between finishing and occupancy.

THERMOSTAT: Z-Wave Plus programmable touchscreen thermostat, Energy Star rated, located on main floor. NOTE: Z-WAVE PLUS THERMOSTAT IS NEEDED TO COMMUNICATE WITH THE TO BE INSTALLED LYRIC PANEL/SECURITY SYSTEM.

15500 PLUMBING

Plumbing contractor shall provide all labor and materials and perform all plumbing work of every nature whatsoever to be done. All plumbing shall be properly installed and all connections thoroughly tested, and shall be installed according to local ordinance.

See plan for water line/meter location. Provide gas line connection and pipe to clothes dryer and range locations. Provide for all fixtures, supply lines, drain lines. full port ball type shut-off valves & escutcheon plates.

WATER PIPING: PEX tubing and Type M copper tubing may be used for water piping when piping is above ground, as U.P.C. No exposed pex in finished areas. Exposed pipe in finished areas to be chromed copper with matching Escutcheons

Standards. NOTE: All copper is to be soldered (no compression fittings) & all PVC fittings glued. All PEX to be Zurn or approved equal with polymer fittings No water, soil, or waste pipe shall be installed or permitted outside of a building or in an exterior wall, unless where necessary, adequate provision is made to protect such pipe from freezing. Piping subject to undue corrosion, erosion, or mechanical damage shall be protected in an approved manner. Insulate exposed hot and cold water mains with closed cell polyethylene slip-on pipe insulation, sized to fit the pipe's diameter. Seal seams with either 5 mil Pipe Insulation sealing tape or Closure Clips designed for pipe insulation placed every 4 inches. Seal all butt joints between sections of pipe with 5 mil Pipe Insulation sealing tape. Neatly miter all angled junctions.

WATER HEATER: Provide a Energy Star rated, 50-gallon heat pump water heater with a UEF equal or greater than 3.75 and First Hour Rating of 67 gallons or better. Rheem Performance Prestige ProTerra model PROPH50 T2 RH375-30 or AO Smith Voltex model HPTU-50N or approved equal.

Include pressure & temperature relief valve/discharge tube to within 6" of floor, condensate line, owner's use and care manual and all duct work if required to vent to exterior. Provide separate 30 amp electrical circuit. HWH to be installed with a polypropylene (plastic) drain pan (not aluminum).

PLUMBING FIXTURES: to be as follows:

All bathroom sink faucets and showerhead to be WaterSense labeled.

TUB & SHOWER: Sterling Advantage™, 60" x 30" x 72" Product #: 61030126 with backer boards; complete with lever operated pop up drain and overflow, PVC waste, single lever shower diverter, shower rod.

TUB & SHOWER FAUCET: Delta tub/shower faucet and a shower head with a maximum 1.5 GPM flow rate. Provide shower curtain rod screwed into wall.

PEDESTAL SINK: Sterling 442124 Sacramento 21" x 18" with 4" faucet holes, or approved equal. Color to be white.

PEDESTAL & VANITY FAUCETS: Sterling 1.0 GPM or less, or approved equal

TOILETS: American Standard FloWise Compact Cadet 1.28 GPF low-flo toilet in white, or any commode tested through the latest "Maximum Performance" (MaP) testing sponsored by Canadian Water and Wastewater Association (CWWA), the California Urban Water Conservation Council (CUWCC), the U.S.-Canadian Alliance for Water Efficiency (AWE) and Veritec Consulting Inc. that has shown to score 800 or better on the MaP Flush Performance test (grams of solid waste removed in a single flush). Include a manufacturer's approved plastic or pressed wood white seat, supply pipe, shut-off valve, and wax seal.

KITCHEN SINK: 22 gauge 33"x22"x7" double bowl, stainless steel, self rimming kitchen sink.

KITCHEN FAUCET: Delta, chrome faucet, rated at **1.5 GPM or less**, with a lifetime drip-free warranty, **Tub/Shower Faucet:** chrome plated brass shower head with a maximum 1.5 gallons per minute flow rate. Include arm where required. Note: any low-flow showerhead should be controlled by a valve that has been designed, tested, and verified to function safely at the reduced flow rate.

HOSE BIBBS: Provide 2 anti-siphon, frost-proof hose bibs as located on plan.

Floor drains: Provide in utility area basement – see plan.

Gas Dryer: Pipe to dryer location and provide valve. Gas Range: Pipe to range location and provide valve. Install water line to refrigerator. Provide hookups for washer and dryer. Location shown on plan.

Plumber to provide spec sheets showing fixtures installed meet the specified flow rates.

DIVISION 16 –ELECTRICAL

16100 ELECTRICAL WIRING / SWITCHES & OUTLETS / LIGHTING FIXTURES

All work shall be in accordance with all codes, rules and regulations of governing agencies and shall comply with the requirements of the serving power and communications companies. Aluminum wire shall not be used in electrical wiring within the dwelling unit.

INSTALLATION

1. All equipment installed outdoors and exposed to weather shall be “weather-proof”.
2. Receptacles in kitchen and bathroom shall be installed above work top unless otherwise noted on plans.
3. Receptacles shall be installed vertically at 12” (approx.) above floor.
4. Wall switches to be above floor as determined by the Architect (42” above floor, unless noted otherwise).
5. Provide two 20-amp small appliance circuits at the Kitchen, Dining Room, and Pantry.
6. Provide a separate 20-amp laundry circuit at basement laundry.
7. Provide ground fault circuit interrupter (GFI) protection at all Bathroom, Powder Room, outdoor receptacles, garages and within 4’-0” of the kitchen sink.
8. Receptacles shall be installed to that no point along with floor line in any wall space more than 6 feet, measured horizontally, from an outlet in that space.
9. In kitchen and dining areas a receptacles outlet shall be installed at each counter space wider than 12 inches.
10. A receptacle outlet shall be installed in any usable wall space 2 feet or more in width.
11. All equipment and materials furnished and installed under this section, shall be guaranteed by the Contractor for a period of one year from the date of acceptance of the work by the Owner

Service to be 200 Amp. Provide 200 Amp. /20 circuit breaker capacity. Minimum 6 circuits.

Circuit breaker service location shall be in Mechanical area.

Provide separate furnace circuits.

Service wiring to be provided for: Range, micro-hood, bath fans, TV-cable outlets, sump pump and attic radon fan. Install underground service to garage. All by electrical contractor.

SWITCHES AND OUTLETS

Provide wall switches and duplex receptacle outlets as indicated and as required by the current National Electric Code. Switches to be silent type. Color shall be white for switches, outlets and cover plates.

Provide outlet for for portable basement dehumidifier unit and sump pump. **Install audible GFCI outlet at sump pump outlet.**

Garbage Disposer: install on circuit separate from dishwasher and provide outlet and switch.

Provide dedicated outlet for range and dryer with 20 Amp service.

Provide switched outlet for radon control fan in attic.

Provide outlet for security system next to electrical panel box.

Exterior receptacles: Provide one GFCI WP at each exterior door as indicated on drawings.

Garage: two outlets and a ceiling-mounted receptacle for a garage door opener.

Garage: install a 208/240V 30A receptacle in garage. Identify this circuit in the electrical panel as "Electric Vehicle Charging."

Solar PV Ready: Install 1" electric metallic tube (EMT) conduit or other 1" code compliant conduit from the attic space to within 8 feet of the electric service panel in mechanical area that terminates to a junction box. Cap and label both ends "Solar PV Ready".

Install or reserve space in electrical panel for future installation of a dual pole circuit breaker for use by the PV system. Label as "Future PV" in electrical panel.

ASHP Ready- Individual branch circuit outlet installed to facilitate future wiring for heat pump installation. Circuit labeled as "For future Heat Pump."

Door Chimes: Provide front door operation. "Nutone" or equal by electrical.

Smoke Detectors: Provide and install hardwired photoelectric smoke detectors with battery back-up, one per floor, as well as one per bedroom, and others to code.

Carbon Monoxide Detector: Provide and install hardwired carbon monoxide detectors in each sleeping room and additional if needed per code requirements.

Telephone / data / cable TV - Cat5 wiring and receptacles to be provided, three (3) jacks: one each at Kitchen, Living Room and Bedroom #1.

LIGHTING –

All light fixtures to be Energy Star qualified, bulbs provided to be LEDs only with minimum efficacy of 45 lumens/watt. Exterior fixtures equipped with daylight sensors (photocells) or timers/ motion sensors. Any selectable lighting to be set @ 3000K. Contractor is responsible for providing light fixtures and ceiling fans. **Owner/Project Manager will select fixtures with the \$1,800 light fixture allowance.** Electrician to install light fixtures per plans.

At rear of house provide a double flood motion light at sufficient elevation to illuminate rear yard; controlled by an interior switch. Garage to have motion or dusk-to-dawn photo sensor light above overhead door and wall mount fixture at service door with switch on interior of garage.

SECURITY SYSTEM

Owner will provide for security system and installation. Coordinate with Owner, electrical and other sub-contractors on installation of system by others. Basic system should include wiring of all exterior first floor doors, installation of motion detectors at first floor and basement. Contractor is responsible for all false alarm call and fines from City of Minneapolis during construction until the issuance of the Cert of Occupancy.

Items highlighted in Green are either Enterprise Green Communities requirements, Energy Star for New Homes V3.2 requirements, or DOE Zero Energy Ready Home (ZERH) Version 2 requirements. Items highlighted in orange are Indoor airPLUS construction specifications as part of EPA Indoor airPLUS V1 (Rev. 04). Any questions regarding these requirements please contact the Project Manager.

PRG – INFILL SINGLE FAMILY

FOLK ELEVATION

2203 OLIVER AVE. N., MPLS.

SQUARE FOOTAGES

| | |
|-------------|--------------------------|
| FOUNDATION | - 912 SQ. FT. UNFINISHED |
| MAIN FLOOR | - 912 SQ. FT. FINISHED |
| UPPER FLOOR | - 944 SQ. FT. FINISHED |
| GARAGE | - 440 SQ. FT. |
| PORCHES | - 120 SQ. FT. |

ZONING REQUIREMENTS

ZONED UN2 – URBAN NEIGHBORHOOD DISTRICT SUBJECT TO BF12 – INTERIOR 2 BUILT FORM OVERLAY DISTRICT

MINIMUM LOT AREA – 5,000 SQ. FT.

MINIMUM LOT WIDTH – 40 FEET

MINIMUM FLOOR AREA RATION – 0.5 OR 2,500 SQ. FT. OF GROSS FLOOR AREA, WHICHEVER IS GREATER

MAXIMUM LOT COVERAGE – 45% BY STRUCTURES

MAXIMUM IMPERVIOUS SURFACE COVERAGE – 60%

MAXIMUM HEIGHT – 2.5 STORIES OR 28 FT. (THE HIGHEST POINT OF A GABLE, HIP OR GAMBREL ROOF SHALL NOT EXCEED 33 FEET)

BUILDING SETBACKS DETERMINED BY ZONING DISTRICT (THE REQUIRED FRONT YARD SHALL BE INCREASED WHERE THE ESTABLISHED FRONT YARD OF THE CLOSEST PRINCIPAL BUILDING ORIGINALLY DESIGNED FOR RESIDENTIAL PURPOSES LOCATED ON THE SAME BLOCK FACE ON EITHER SIDE OF THE PROPERTY EXCEEDS THE FRONT YARD REQUIRED BY THE ZONING DISTRICT. IN SUCH CASE, THE REQUIRED FRONT YARD SHALL BE NOT LESS THAN SUCH ESTABLISHED FRONT YARD PROVIDED THAT WHERE THERE ARE PRINCIPAL STRUCTURES ORIGINALLY DESIGNED FOR RESIDENTIAL PURPOSES ON BOTH SIDES OF THE PROPERTY. THE REQUIRED FRONT YARD SHALL BE NOT LESS THAN THAT ESTABLISHED BY A LINE JOINING THE NEAREST FRONT CORNERS OF BOTH BUILDINGS.)

BUILDING SETBACKS: SIDE – DETERMINED BY LOT WIDTH

BUILDING SETBACKS: REAR – DETERMINED BY LOT WIDTH

ACCESSORY STRUCTURES:

A DETACHED ACCESSORY STRUCTURE SHALL NOT EXCEED THE HEIGHT OF THE PRINCIPAL STRUCTURE OR 12 FT., WHICHEVER IS LESS.

THE MAXIMUM FLOOR AREA OF ALL DETACHED ACCESSORY STRUCTURES, AND ANY ATTACHED ACCESSORY USE DESIGNED OR INTENDED TO BE USED FOR THE PARKING OF VEHICLES, SHALL NOT EXCEED 676 SQ. FT. OR 10% OF THE LOT AREA, WHICHEVER IS GREATER, NOT TO EXCEED 1,000 SQ. FT.

NO DETACHED ACCESSORY BUILDING OR OPEN PARKING SPACE SHALL BE LOCATED CLOSER THAN 6 FEET FROM A DWELLING.

THE INTERIOR SIDE YARD REQUIREMENT FOR A DETACHED ACCESSORY BUILDING MAY BE REDUCED TO 1 FOOT WHEN THE ENTIRE ACCESSORY BUILDING IS LOCATED IN THE REAR 40 FEET OR REAR 20% OF THE LOT, WHICHEVER IS GREATER, PROVIDED THAT THE PRINCIPAL STRUCTURE ON THE ADJOINING LOT HAS ITS REAR WALL AT LEAST 40 FEET FROM THE REAR LOT LINE.

THE REAR YARD REQUIREMENT FOR A DETACHED ACCESSORY BUILDING MAY BE REDUCED TO 1 FOOT, EXCEPT WHERE VEHICLE ACCESS DOORS FACE THE REAR LOT LINE, IN WHICH CASE NO REDUCTION OF THE REQUIRED YARD IS PERMITTED. (AS PER CITY OF MINNEAPOLIS ZONING CODE)

SHEET INDEX

CS – COVER SHEET

A1 – FOUNDATION PLANS

A2 – MAIN AND UPPER FLR. PLANS / INT. ELEV.

A3 – ELEVATIONS / ROOF PLANS

A4 – SECTIONS / DETAILS

E5 – ELECTRICAL PLANS

BW – BRACEWALL PLANS

BW2 – BRACEWALL DETAILS

SYMBOLS

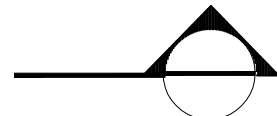
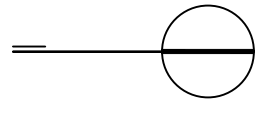
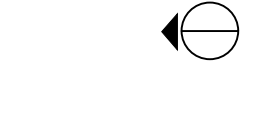
-  – SECTION CUT THROUGH
-  – DETAIL CUT THROUGH
-  – ELEVATION MARKER



REV. DATE: 4-26-2024

CS

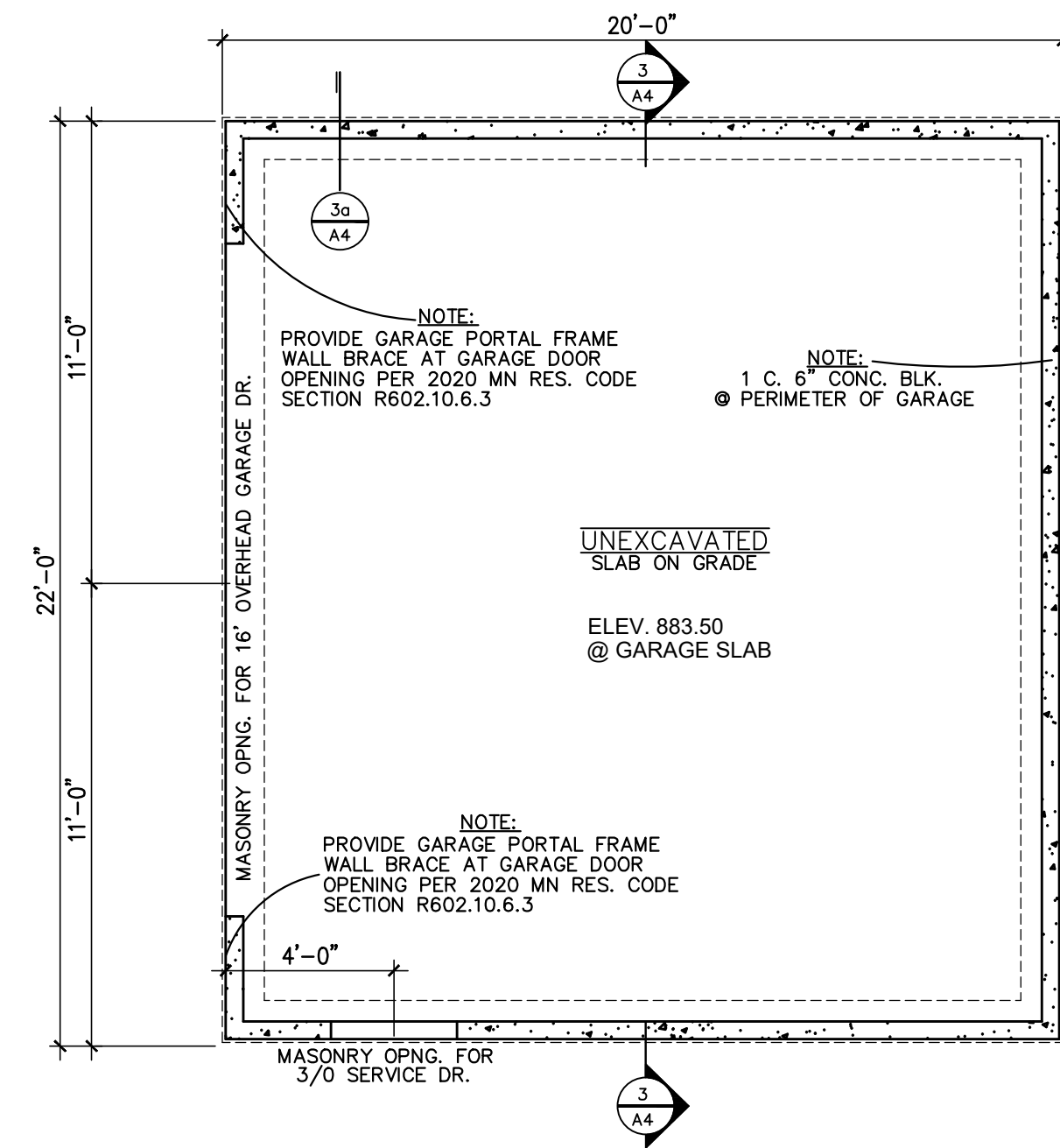

2 GARAGE FDN. PLAN
SCALE: 1/4" = 1'-0"

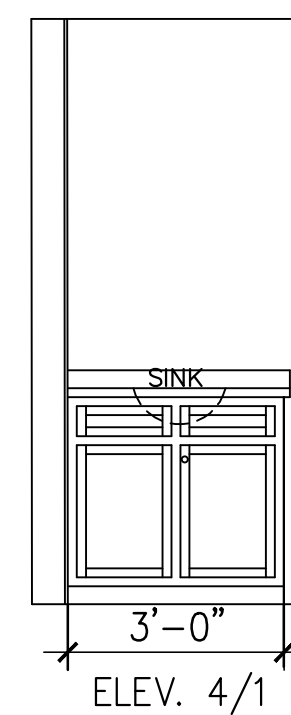

3 FUT. BATH VANITY ELEV.
SCALE: 3/8" = 1'-0"

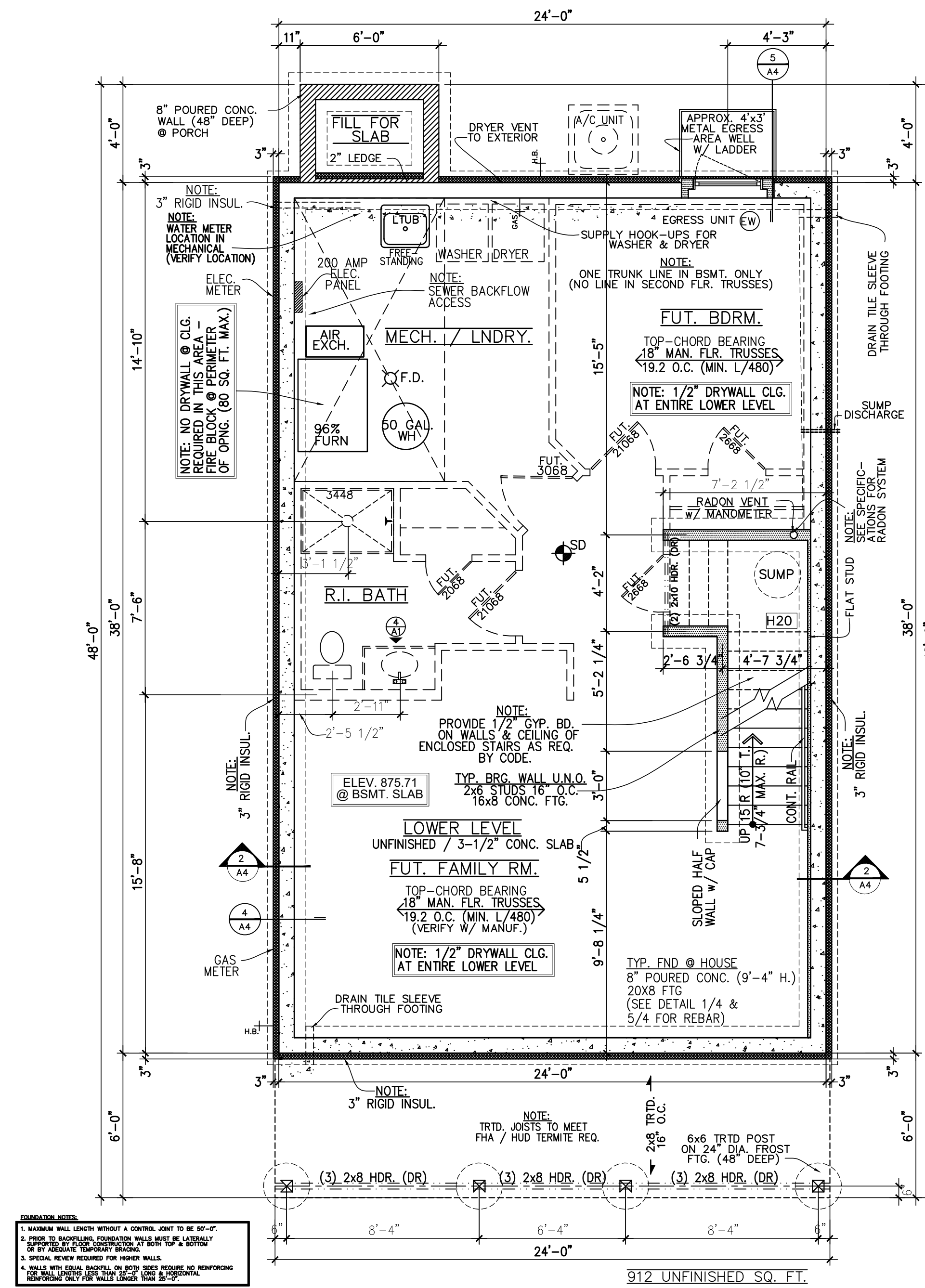

1 BASEMENT PLAN
SCALE: 1/4" = 1'-0"

| WINDOW SCHEDULE (ANDERSEN 100 SERIES) | | |
|---------------------------------------|----------------|---------------|
| UNIT | LABEL | ROUGH OPENING |
| A | 2W - 2040 SH | 4'-0" x 4'-0" |
| B | 2020 AWN. | 2'-0" x 2'-0" |
| C | 2W - 2020 AWN. | 4'-0" x 2'-0" |
| D | 2050 SH | 2'-0" x 5'-0" |
| E | 2W - 3656 SH | 7'-0" x 5'-6" |
| F | * 3050 SH | 3'-0" x 5'-0" |
| G | 3036 SH | 3'-0" x 3'-6" |
| H | * 2 - 3050 SH | 6'-0" x 5'-0" |
| J | * 3650 SH | 3'-6" x 5'-0" |
| K | * 2 - 3650 SH | 7'-0" x 5'-0" |
| L | 2040 FX | 2'-0" x 4'-0" |
| M | 5020 FX | 5'-0" x 2'-0" |
| N | 2040 SH | 2'-0" x 4'-0" |
| EW | * 3040 CSMT. | 3'-0" x 4'-0" |

* DENOTES EGRESS PER IRC REQ.

FOUNDATION NOTES:
 1. MASONRY WALL LENGTH WITHOUT A CONTROL JOINT TO BE 8'-0".
 2. PROVIDE ANCHORAGE/REINFORCING WHERE ANY WALL IS SUPPORTED BY ANOTHER WALL OR COLUMN.
 3. SPECIAL REVIEW REQUIRED FOR HOLLOW WALLS.
 4. WALLS WITH EXPOSED REINFORCING OR POLE REINFORCING REQUIRE NO REINFORCING.
 5. REINFORCING ONLY FOR WALLS UNDER 8" THICK.

DATE: 4-28-2024
 DRAWN BY: MBG
 REVISIONS:
 REVISIONS:
 REVISIONS:
 APPROVED FOR CONSTRUCTION: _____
 INITIALS: _____
 DATE: _____

© 2013 PRG-INFILL SGL. FAMILY UNAUTHORIZED USE OF THIS PLAN IS A VIOLATION OF THE U.S. COPYRIGHT ACT, TITLE 17, OF THE U.S. CODE.

GENERAL NOTES & DISCLAIMERS
 These drawings have been prepared to meet generally accepted industry standards. Likewise, building code requirements may vary with location & change from time to time. Before starting construction, the builder must review & be responsible for all details & dimensions, and insure that all const. shall conform to latest building codes.

OWNER: PRG - INFILL SINGLE FAMILY
 PROJECT ADDRESS: 2203 OLIVER AVE. N., MPLS.
 DEVELOPMENT: (FOLK)

LOT:
 BLOCK:
 ADD.:

PN:
 TITLE: FDN
 SHEET: A1

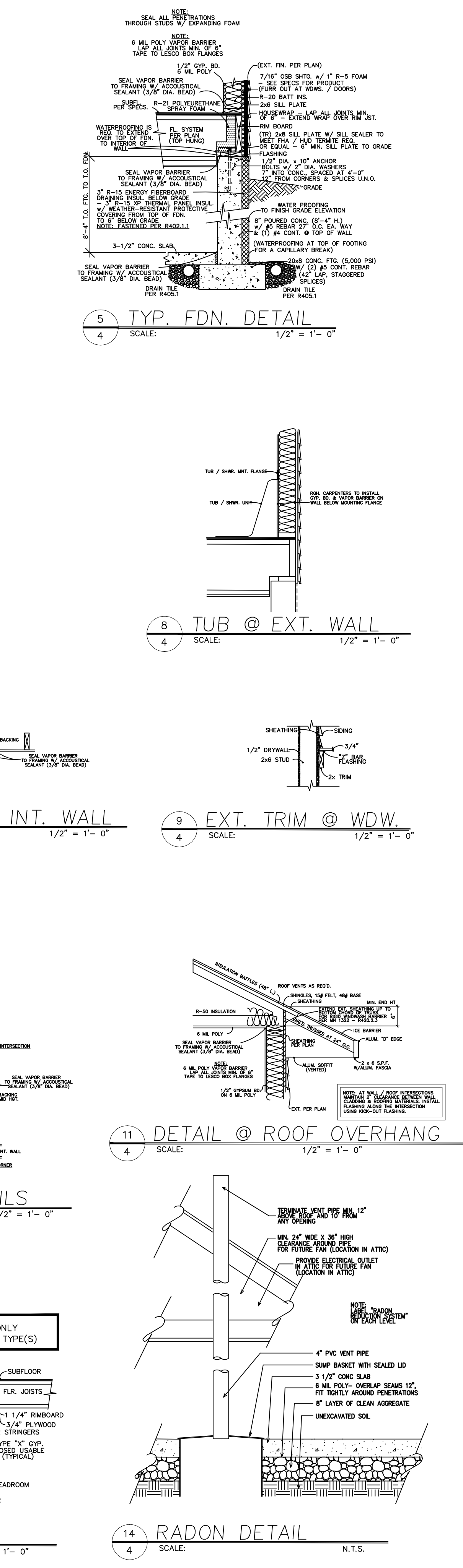
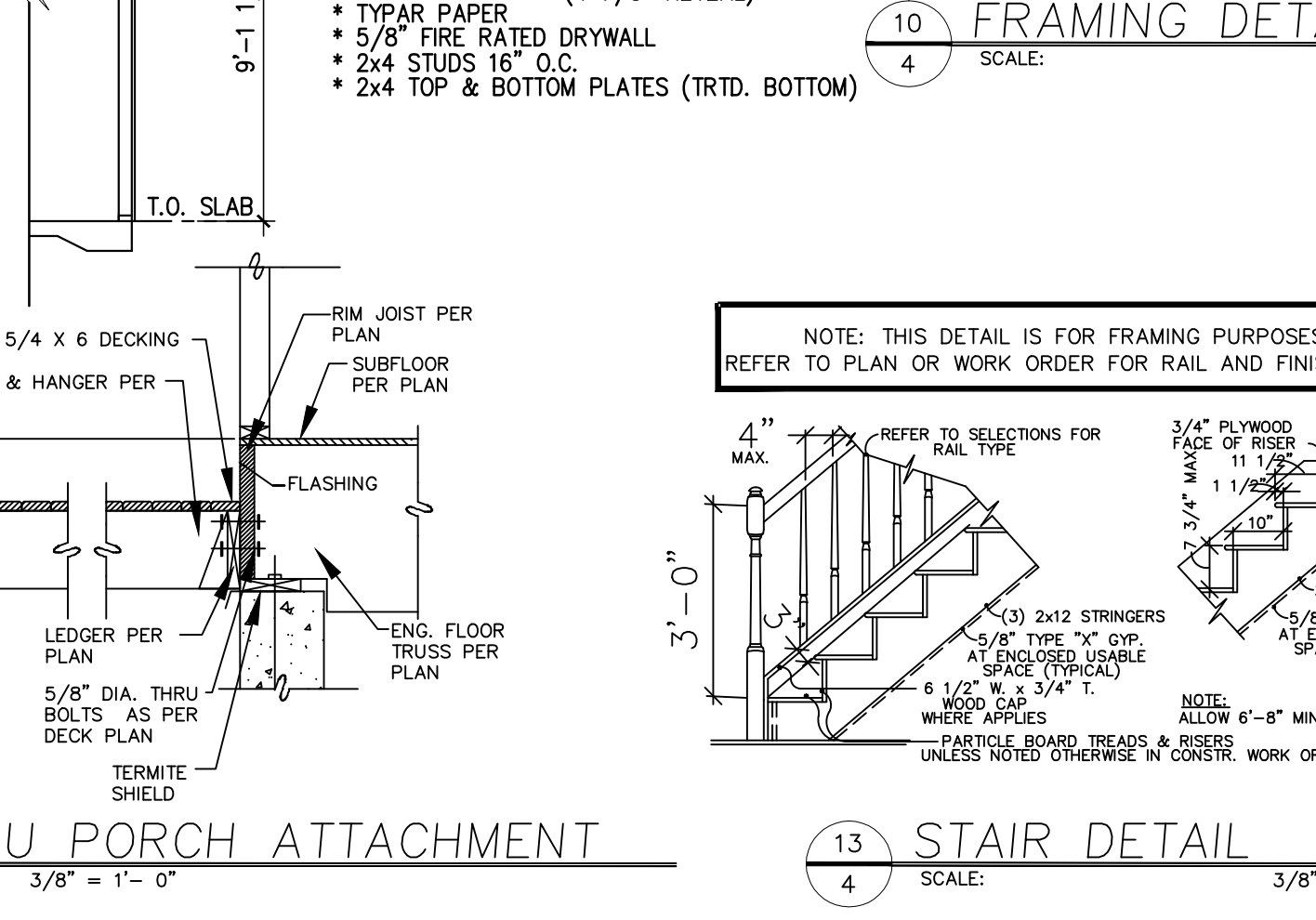
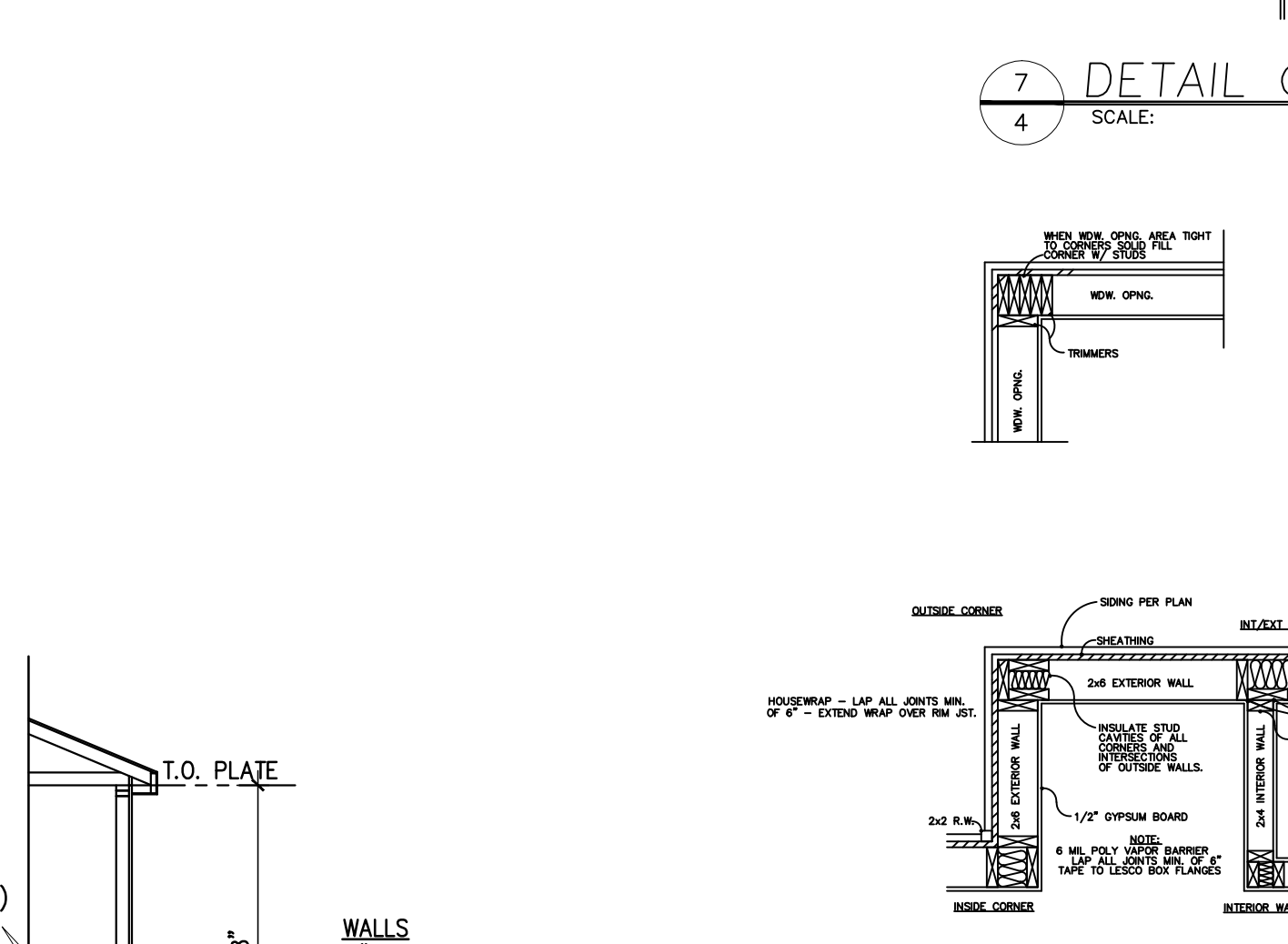
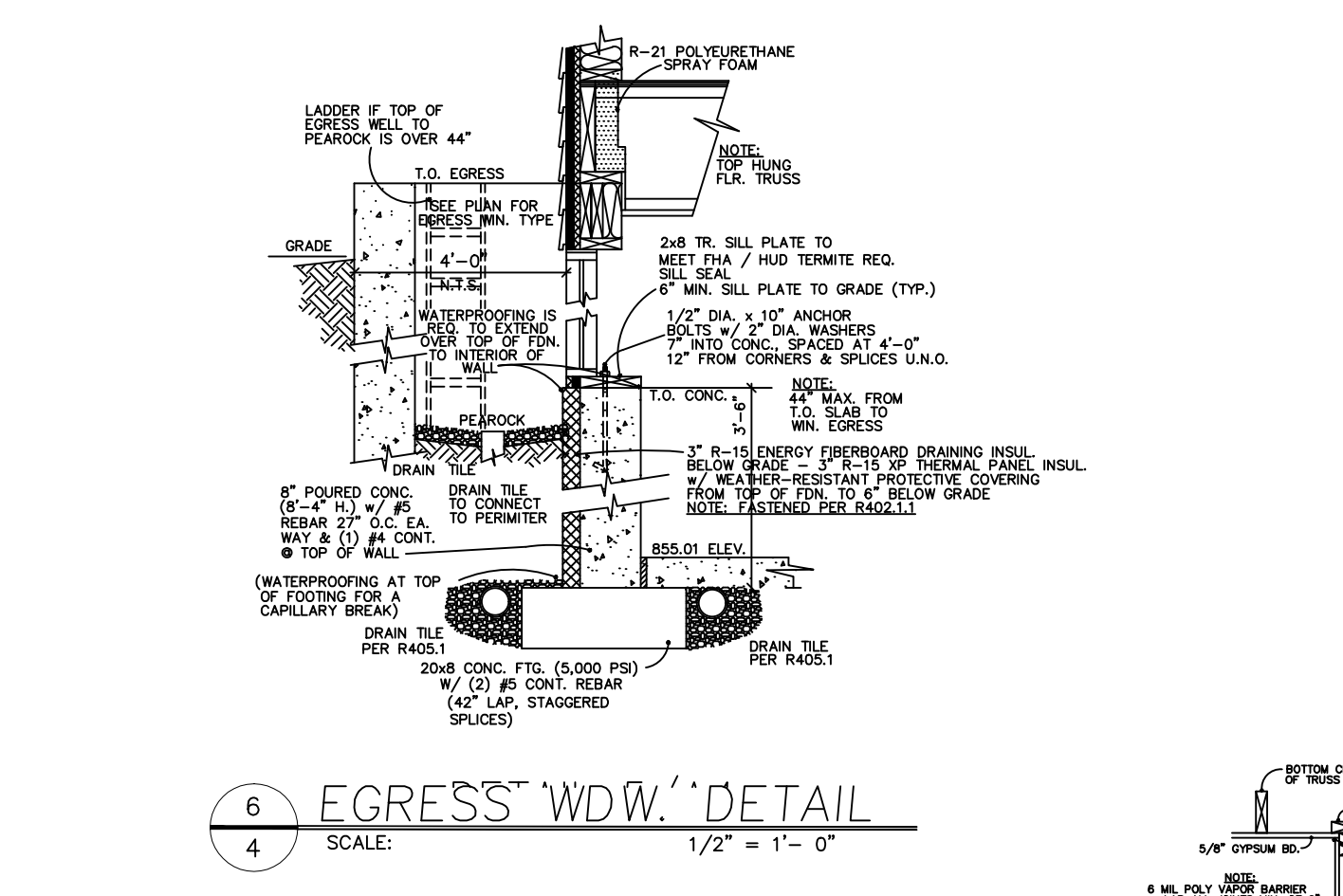
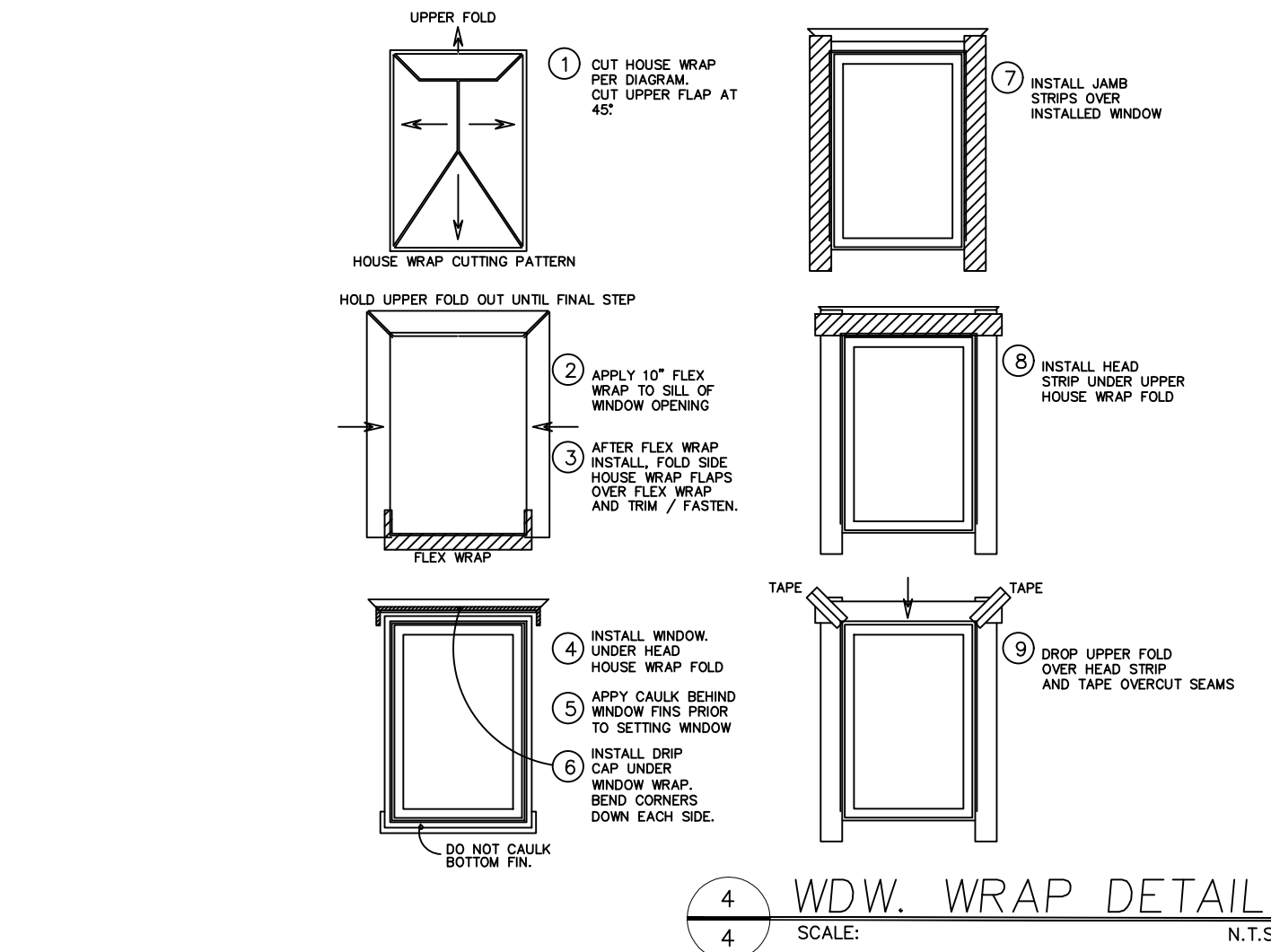
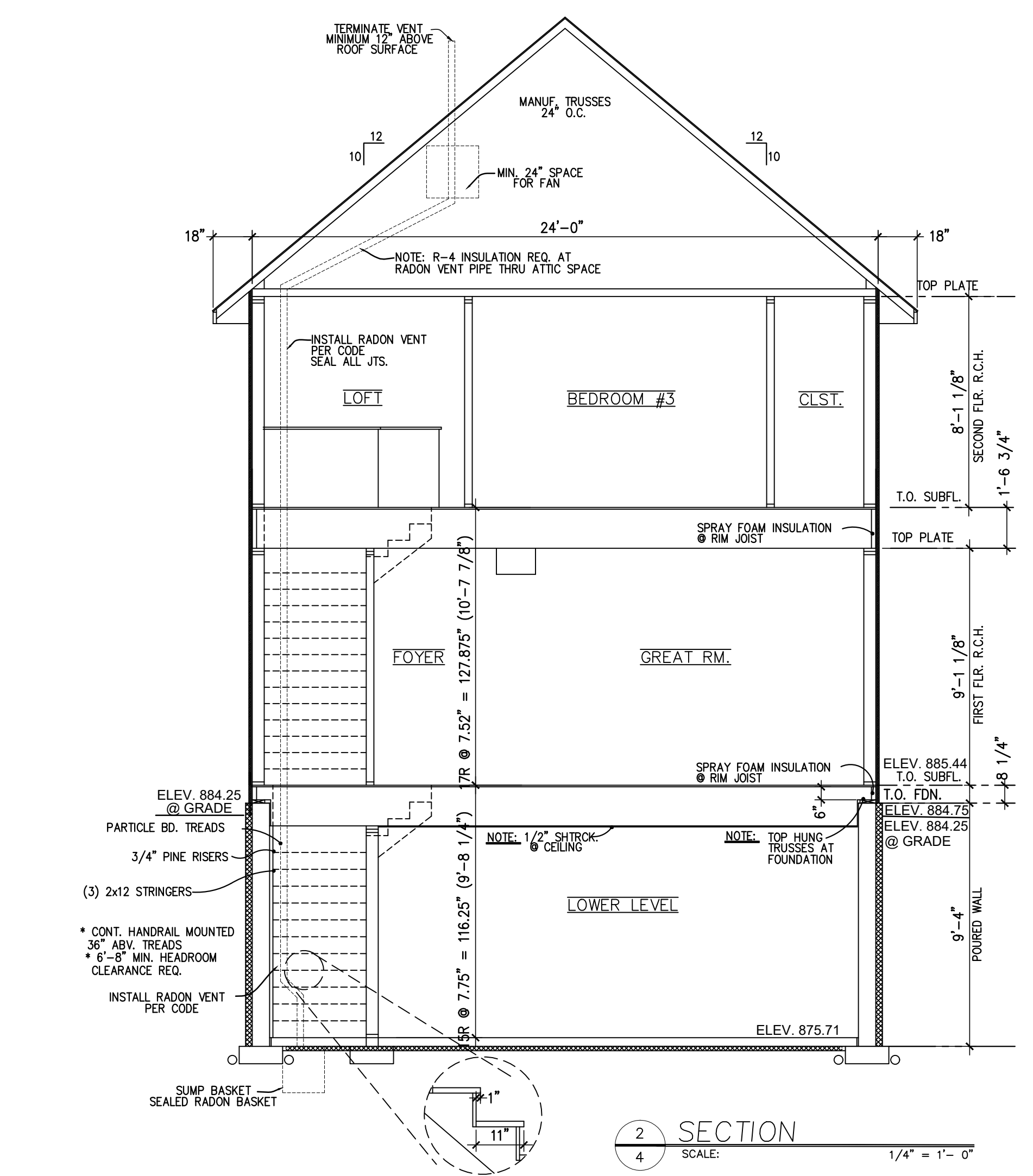
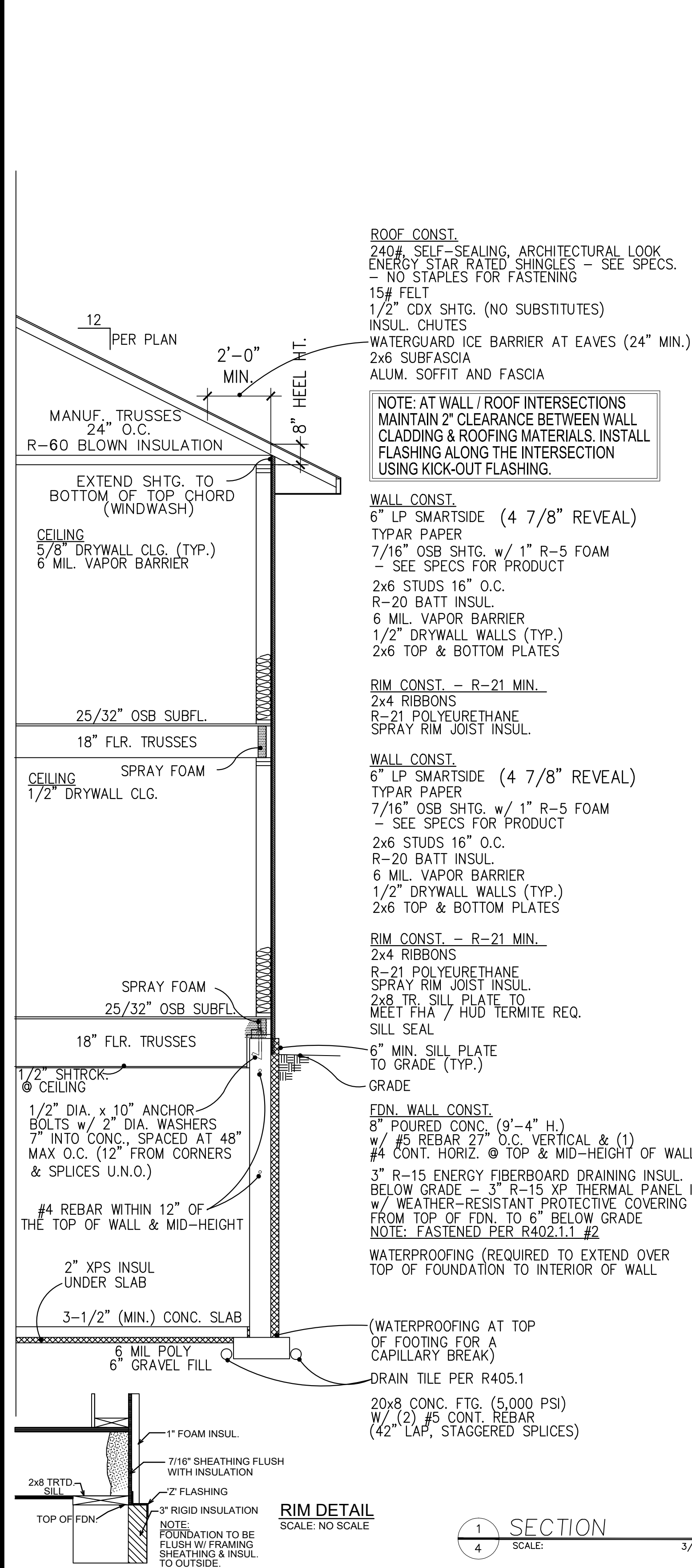

| COMPRESSION STRENGTH OF CONCRETE | |
|----------------------------------|-----------|
| POURED WALLS | 4,000 PSI |
| CONCRETE FOOTINGS | 5,000 PSI |
| CONCRETE FLOOR | 3,000 PSI |
| GARAGE PERIMETER FOOTING | 3,500 PSI |

DATE: 4-26-2024
 DRAWN BY: MBC
 REVISIONS:
 INITIALS: _____
 DATE: _____

APPROVED FOR CONSTRUCTION

© 2013 PRG - INFILL SCL FAMILY UNAUTHORIZED USE OF THIS PLAN IS A VIOLATION OF THE U.S. COPYRIGHT ACT, TITLE 17, OF THE U.S. CODE.

GENERAL NOTES & DISCLAIMERS
 These drawings have been prepared to meet generally accepted professional standards. However, local variations may vary with location, and change from time to time. Before starting construction, the builder must review & be responsible for all details & dimensions, and insure that all plans conform to latest building codes.

OWNER: PRG - INFILL SINGLE FAMILY
 PROJECT ADDRESS: 2203 OLIVER AVE. N., MPLS.
 DEVELOPMENT: (FOLK)

LOT:
 BLOCK:
 ADD.:

PN:
 TITLE: SECT
 SHEET: A4

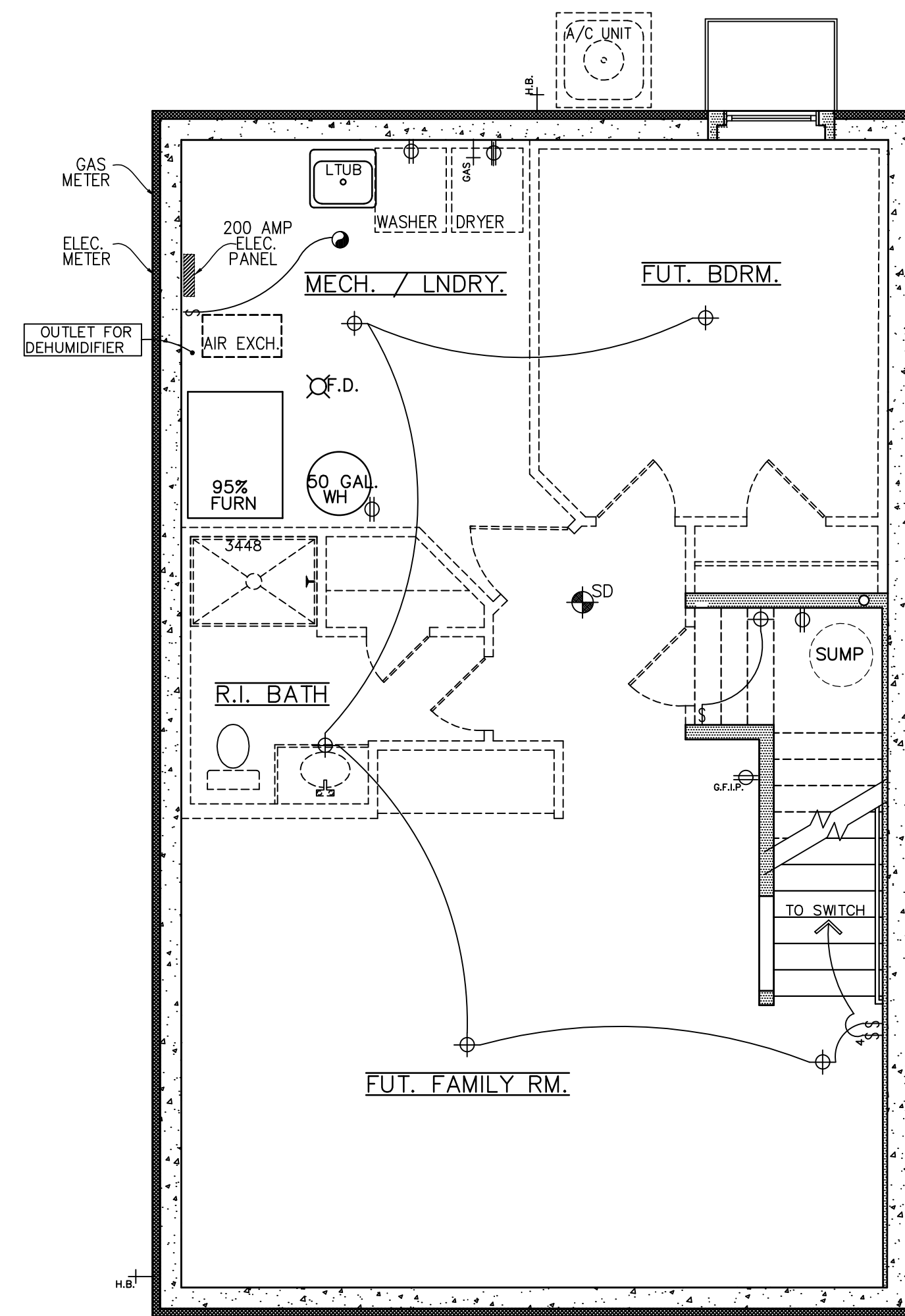

1 FOUNDATION ELECTRICAL PLAN
SCALE: 1/4" = 1'-0"

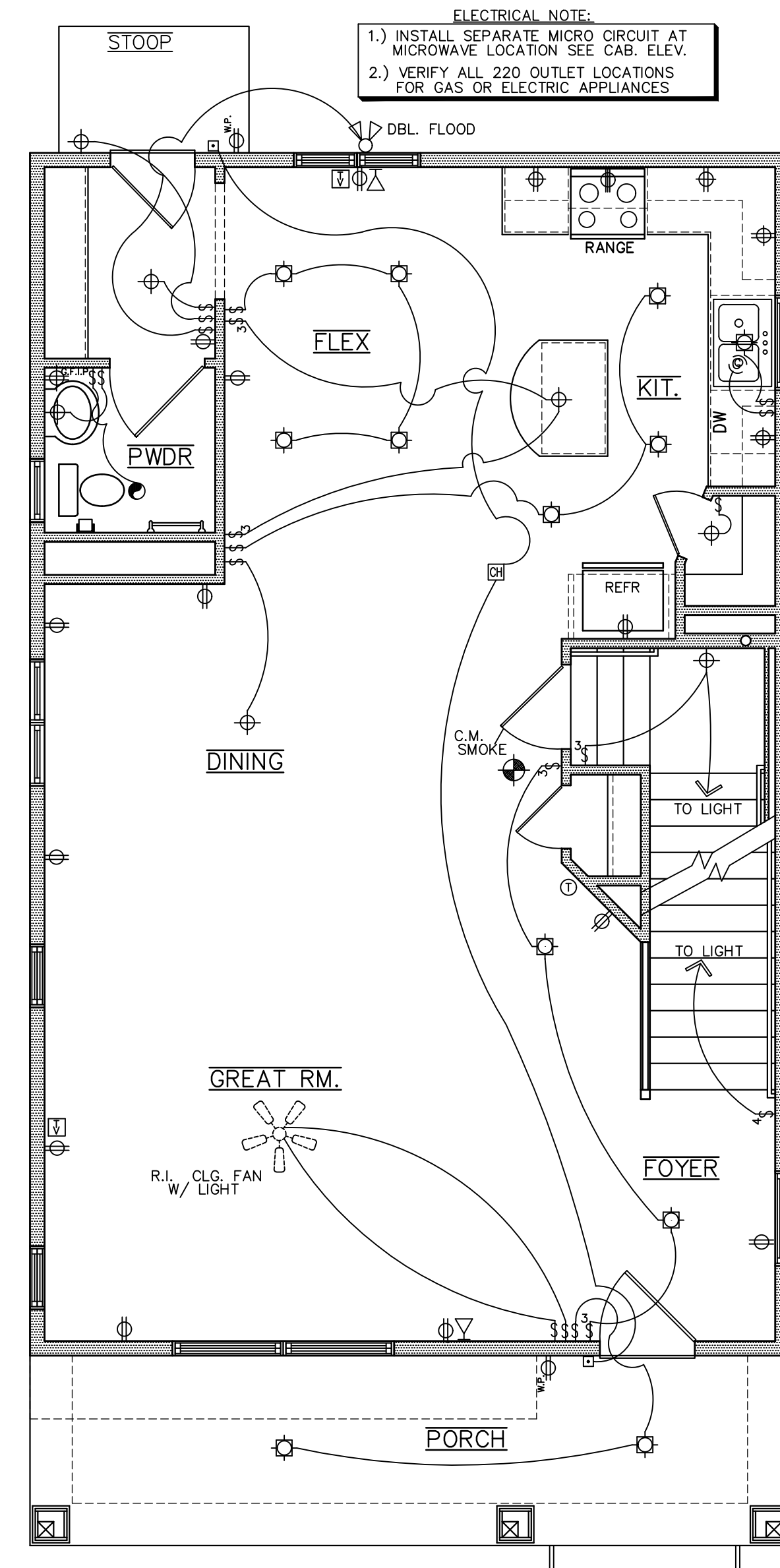

2 MAIN FLR. ELECTRICAL PLAN
SCALE: 1/4" = 1'-0"

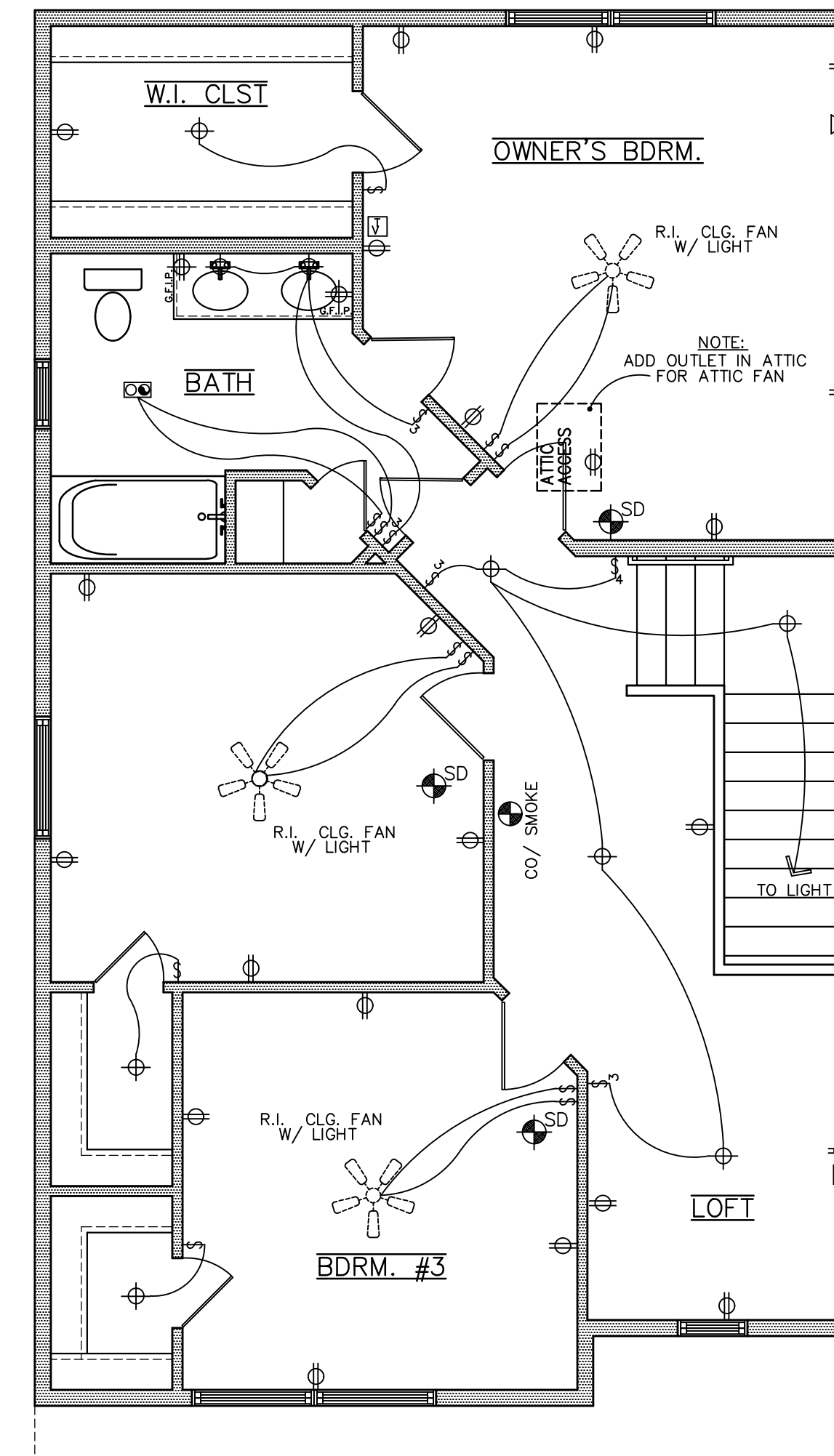

3 UPPER FLR. ELECTRICAL PLAN
SCALE: 1/4" = 1'-0"

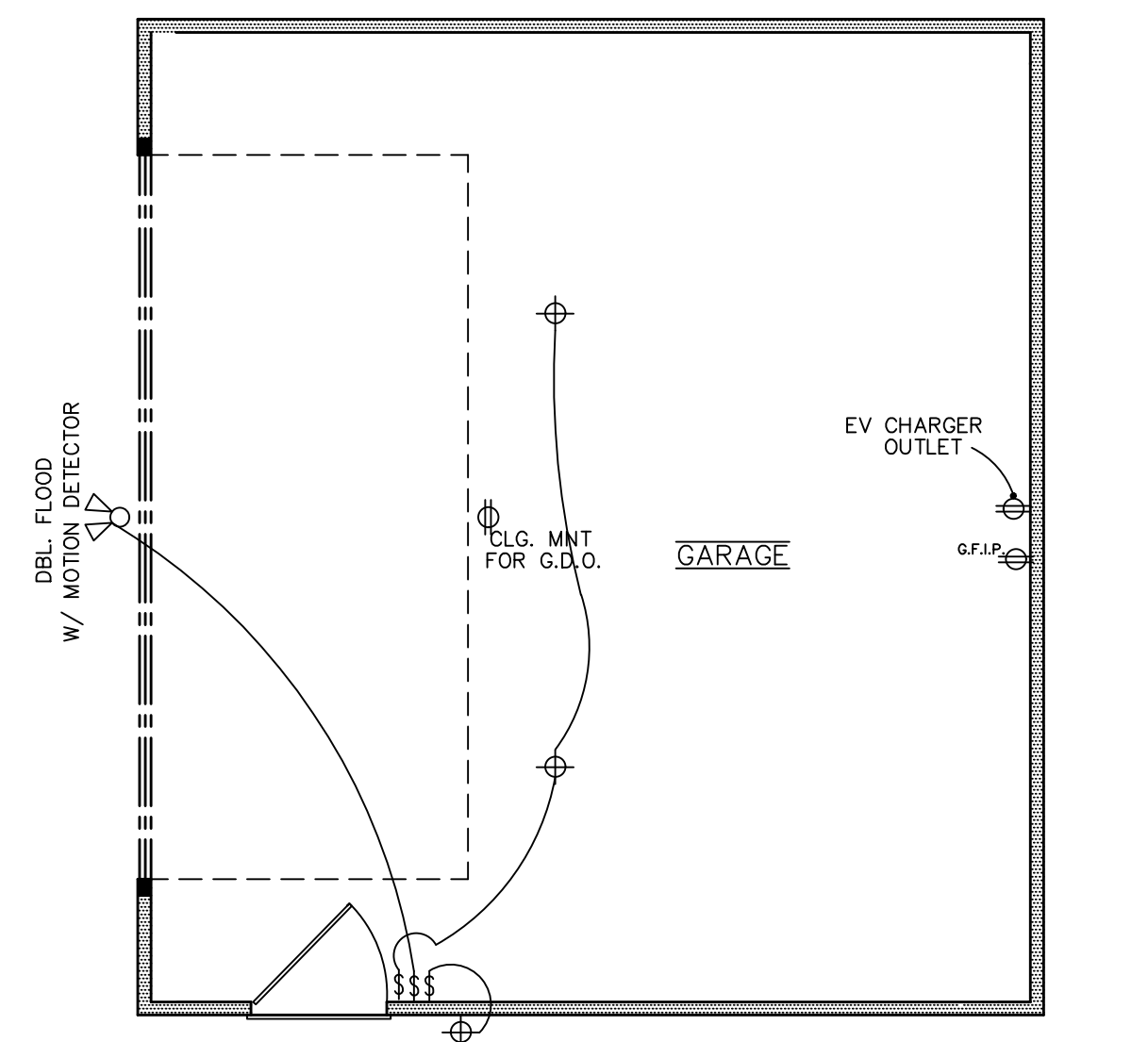

4 GARAGE ELECTRICAL PLAN
SCALE: 1/4" = 1'-0"

ELECTRICAL KEY

- ⊕ DUPLEX CONVENIENCE OUTLET
 - ⊕ DUPLEX OUTLET ABOVE COUNTER
 - ⊕ WEATHERPROOF DUPLEX OUTLET
 - ⊕ DUPLEX OUTLET (GROUND FAULT PROTECTED)
 - ⊕ HALF-SWITCHED DUPLEX OUTLET
 - ⊕ DUPLEX OUTLET IN FLOOR
 - ⊕ 220 VOLT OUTLET
 - ⊕ WALL SWITCH
 - ⊕ THREE-WAY SWITCH
 - ⊕ FOUR-WAY SWITCH
 - ⊕ CEILING MOUNTED INCANDESCENT LIGHT FIXTURE
 - ⊕ WALL MOUNTED INCANDESCENT LIGHT FIXTURE
 - ⊕ RECESSED INCANDESCENT LIGHT FIXTURE
 - ⊕ RECESSED INCANDESCENT EYE BALL FIXTURE
 - ⊕ LIGHT FIXTURE WITH PULL CHAIN
 - ⊕ TRACK LIGHT
 - ⊕ FLOURESCENT LIGHT FIXTURE
 - ⊕ EXHAUST FAN
 - ⊕ EXHAUST FAN/LIGHT COMBINATION
 - ⊕ CHIMES
 - ⊕ SMOKE DETECTOR
 - ⊕ CARBON MONOXIDE DETECTOR
 - ⊕ TELEPHONE
 - ⊕ TELEVISION
 - ⊕ THERMOSTAT
 - ⊕ ELECTRIC METER
 - ⊕ ELECTRIC PANEL
 - ⊕ SPEAKER
 - ⊕ FAN/LIGHT COMBO PREWIRE, PROVIDE ADEQUATE SUPPORT
 - ⊕ 4 BULB FIXTURE
 - ⊕ 3 BULB FIXTURE
 - ⊕ GARAGE DOOR OPENER OUTLET
 - ⊕ FLUORESCENT LIGHT PER SPEC
- 200 AMP SERVICE LIGHTING PACKAGE: T.B.D.
LINE TO DRYER: T.B.D.

DATE: 4-26-2024
DRAWN BY: MBC
REVISED: _____
REVISED: _____
REVISED: _____

APPROVED FOR CONSTRUCTION INITIALS: _____ DATE: _____

© 2013 PRG-INfill SCL FAMILY UNAUTHORIZED USE OF THIS PLAN IS A VIOLATION OF THE U.S. COPYRIGHT ACT, TITLE 17, OF THE U.S. CODE.

GENERAL NOTES & DISCLAIMERS
These drawings have been prepared to meet generally accepted professional standards. However, local variations may vary with location & change from time to time. Before starting construction, the builder must review & be responsible for all details & dimensions, and insure that the plans meet all current codes in your area. All work shall conform to latest building codes.

OWNER: PRG - INFILL SINGLE FAMILY
PROJECT ADDRESS: 2203 OLIVER AVE. N., MPLS.
DEVELOPMENT: (FOLK)

LOT: _____
BLOCK: _____
ADD.: _____

PN: _____
TITLE: ELEC
SHEET: E5

KEMPER & ASSOCIATES INC.
PROFESSIONAL LAND SURVEYORS

721 OLD HIGHWAY 8 N.W.
NEW BRIGHTON, MINNESOTA 55112
651-631-0351
FAX 651-631-8805
email: kemper@pro-ns.net
www.kempersurveys.com

PROPOSED ELEVATION SUMMARY

FIRST FLOOR = 885.44
TOP OF FOUNDATION = 884.75
BASEMENT FLOOR = 875.71
GARAGE FLOOR = 883.5
GRADE ADJACENT TO HOUSE = 884.25

2203 OLIVER AVENUE NORTH

CITY OF MINNEAPOLIS, HENNEPIN COUNTY, MINNESOTA
(PROPOSED SITE & GRADING AND EROSION CONTROL PLAN)



FRONT OF PROPOSED RESIDENCE
AT 1564 HILLSIDE AVE. N.
(PRG "FOLK" PLAN)

ZONING REQUIREMENTS

ZONED UN2 - URBAN NEIGHBORHOOD DISTRICT

SUBJECT TO BF12 - INTERIOR 2 BUILT FORM OVERLAY DISTRICT

MINIMUM LOT AREA - 5,000 SQ. FT.

MINIMUM LOT WIDTH - 40 FEET

MAXIMUM FLOOR AREA RATIO - 0.5

MAXIMUM LOT COVERAGE - 45%

MAXIMUM IMPERVIOUS SURFACE COVERAGE - 60%

MAXIMUM HEIGHT - 2.5 STORIES, 28 FEET, (THE HIGHEST POINT OF A GABLE, HIP OR GAMBREL ROOF SHALL NOT EXCEED 33 FEET)

BUILDING SETBACKS:

FRONT - 20 FEET (THE REQUIRED FRONT YARD SHALL BE INCREASED WHERE THE ESTABLISHED FRONT YARD OF THE CLOSEST PRINCIPAL BUILDING ORIGINALLY DESIGNED FOR RESIDENTIAL PURPOSES LOCATED ON THE SAME BLOCK FACE ON EITHER SIDE OF THE PROPERTY EXCEEDS THE FRONT YARD REQUIRED BY THE ZONING DISTRICT. IN SUCH CASE, THE REQUIRED FRONT YARD SHALL BE NOT LESS THAN SUCH ESTABLISHED FRONT YARD, PROVIDED THAT WHERE THERE ARE PRINCIPAL BUILDINGS ORIGINALLY DESIGNED FOR RESIDENTIAL PURPOSES ON BOTH SIDES OF THE PROPERTY, THE REQUIRED FRONT YARD SHALL BE NOT LESS THAN THAT ESTABLISHED BY A LINE JOINING THOSE PARTS OF BOTH BUILDINGS NEAREST TO THE FRONT LOT LINE, NOT INCLUDING ANY OBSTRUCTIONS ALLOWED)

SIDE - 5 FEET (HEIGHT LESS THAN 42')
REAR - 5 FEET (HEIGHT LESS THAN 42')

(AS PER CITY OF MINNEAPOLIS ZONING CODE)

ACCESSORY STRUCTURES:

A DETACHED ACCESSORY STRUCTURE SHALL NOT EXCEED 13 FEET. THE WALL HEIGHT SHALL NOT EXCEED 10 FEET AT ANY POINT FROM ADJACENT GRADE TO THE EXTERIOR INTERSECTION OF THE WALL AND THE ROOF RAFTERS FOR HIP, GABLE, GAMBREL, OR FLAT ROOFS AND FOR THE LOW EAVE SIDE FOR SHED ROOFS

THE MAXIMUM FLOOR AREA OF ALL DETACHED ACCESSORY STRUCTURES, AND ANY ATTACHED ACCESSORY USE DESIGNED OR INTENDED TO BE USED FOR THE PARKING OF VEHICLES, SHALL NOT EXCEED 800 SQ. FT. OR 10% OF THE LOT AREA, WHICHEVER IS GREATER

A DETACHED ACCESSORY BUILDING SHALL NOT BE LOCATED CLOSER THAN 6 FEET FROM THE HABITABLE SPACE OF A DWELLING

THE INTERIOR SIDE YARD REQUIREMENT FOR A DETACHED ACCESSORY BUILDING MAY BE REDUCED TO 1 FOOT WHEN THE ENTIRE ACCESSORY BUILDING IS LOCATED IN THE REAR 40 FEET OR REAR 20% OF THE LOT, WHICHEVER IS GREATER, PROVIDED THAT THE ACCESSORY BUILDING SHALL BE LOCATED NOT LESS THAN 10 FEET FROM ANY HABITABLE PORTION OF A PRINCIPAL STRUCTURE ON THE ADJOINING LOT. WHERE THE INTERIOR SIDE YARD IS REDUCED, EAVES, INCLUDING GUTTERS, SHALL NOT BE LESS THAN 6 INCHES FROM THE PROPERTY LINE

THE REAR YARD REQUIREMENT FOR A DETACHED ACCESSORY BUILDING MAY BE REDUCED TO 1 FOOT, EXCEPT WHERE VEHICLE ACCESS DOORS FACE THE REAR LOT LINE, IN WHICH CASE NO REDUCTION OF THE REQUIRED YARD IS PERMITTED. WHERE THE REAR YARD IS REDUCED, EAVES, INCLUDING GUTTERS, SHALL NOT BE LESS THAN 6 INCHES FROM THE PROPERTY LINE

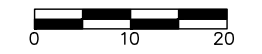
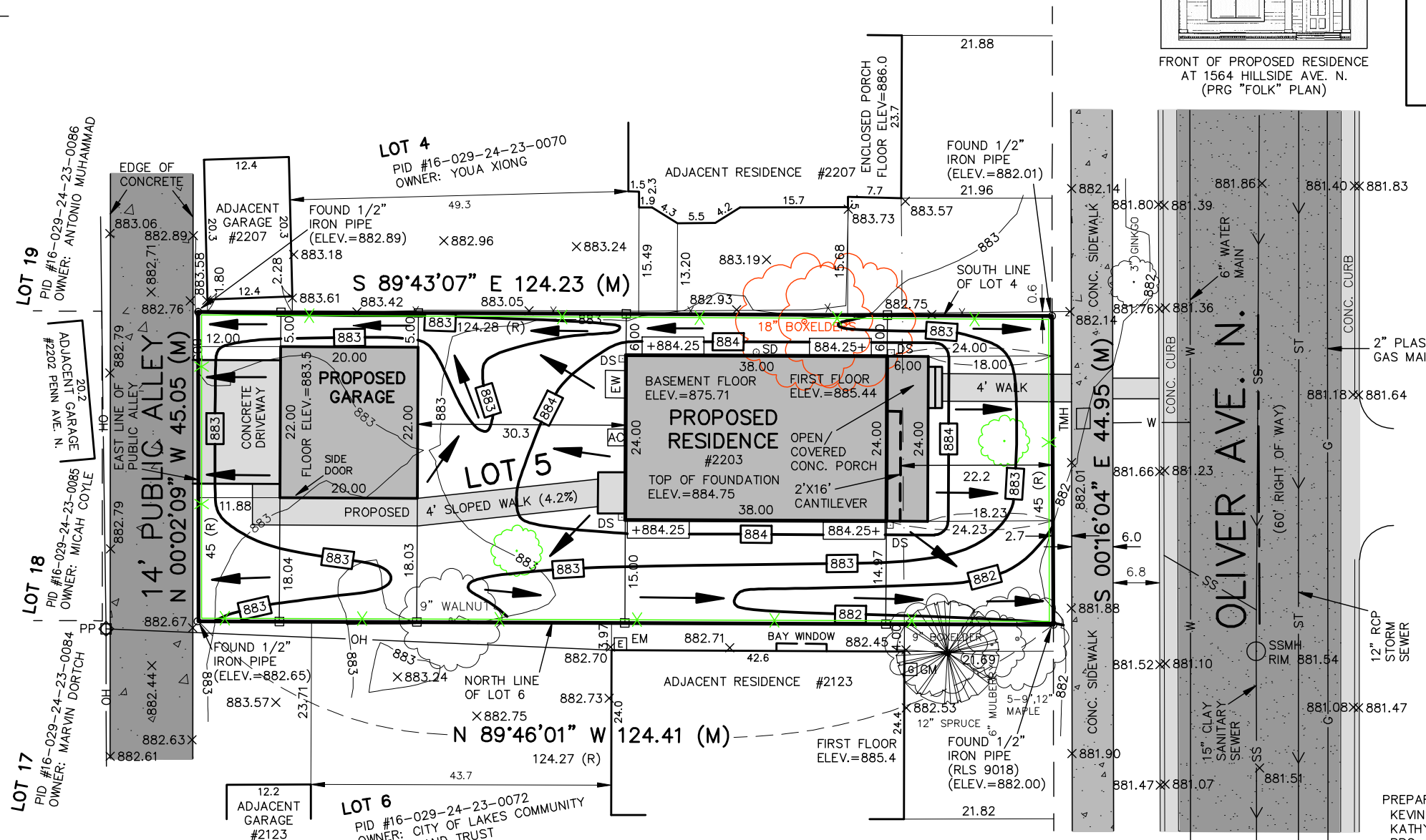

1 INCH EQUALS 20 FEET

BASIS FOR BEARINGS:
HENNEPIN COUNTY
COORDINATE SYSTEM
(NAD83, 1996)

BASIS FOR ELEVATION:
CITY OF MINNEAPOLIS
MONUMENT NO. GPS012
AT THE INTERSECTION
OF 24TH AVE. N. &
IRVING AVE. N.
ELEV.=891.83 (NGVD29)

(VIA REAL TIME GPS
MEASUREMENTS UTILIZING
MINNESOTA DEPARTMENT
OF TRANSPORTATION
VRS NETWORK)

CONTOUR INTERVAL=1/2 FOOT

LEGAL DESCRIPTION

DEED DOC. NO.
A9460716

LOT 005, BLOCK 022,
"FOREST HEIGHTS"

LOT 5 =
5,595 SQ. FT.
OR 0.1284 ACRES

PREPARED FOR:
KEVIN GULDEN, PROJECT MANAGER
KATHY WETZEL-MASTEL, EXECUTIVE DIRECTOR
PRG, INC.
2017 38TH ST. E.
MINNEAPOLIS, MINNESOTA 55407
612-721-7556
kevin@prginc.org
kathy@prginc.org
FAX 651-925-0422

CERTIFICATION
I HEREBY CERTIFY THAT THIS SURVEY, PLAN,
OR REPORT WAS PREPARED BY ME OR
UNDER MY DIRECT SUPERVISION AND THAT
I AM A DULY LICENSED PROFESSIONAL LAND
SURVEYOR UNDER THE LAWS OF THE STATE
OF MINNESOTA.

Mark D. Kemper
MARK D. KEMPER, PLS 18407

DATED THIS 16TH DAY OF APRIL, 2024

PROPOSED HARDCOVER SUMMARY

HOUSE FOOTPRINT=912 SQ. FT.
FRONT PORCH & STEPS=156 SQ. FT.
REAR STOOP=24 SQ. FT.
GARAGE FOOTPRINT=440 SQ. FT.
CONCRETE DRIVEWAY=230 SQ. FT.
CONCRETE WALKS=274 SQ. FT.
TOTAL IMPERVIOUS SURFACE
COVERAGE=2,036 SQ. FT.
(36.4% OF LOT AREA)

LEGEND

- 883 — EXISTING CONTOUR LINE
- X 882.42 EXISTING SPOT ELEVATION
- PP ○ POWER POLE
- SSM ○ SANITARY SEWER MANHOLE
- EM □ ELECTRIC METER
- GM □ GAS METER
- OH — OVERHEAD UTILITY LINES
- SS — SANITARY SEWER
- W — WATER MAIN/SERVICE
- G — GAS MAIN/SERVICE
- TMH ○ TELEPHONE MANHOLE
- X — CHAIN LINK FENCE
- PROPOSED 2" CALIPER CANOPY MAPLE
- (M) DENOTES DIMENSION MEASURED DURING THE COURSE OF THIS SURVEY
- (R) DENOTES RECORD DIMENSION AS PER PLAT OF FOREST HEIGHTS
- DENOTES SET SURVEY MONUMENT MARKED "KEMPER 18407"
- EW PROPOSED EGRESS WINDOW WELL
- 883 — PROPOSED CONTOUR LINE
- +884.25 PROPOSED SPOT ELEVATION
- DIRECTION OF PROPOSED DRAINAGE
- PROPOSED OFFSET STAKE
- X PROPOSED SILT FENCE
- DS □ PROPOSED DOWN SPOUT
- SD ○ PROPOSED SUMP DISCHARGE
- AC PROPOSED AIR CONDITIONER



CERTIFICATE OF SURVEY

KEMPER & ASSOCIATES INC.
PROFESSIONAL LAND SURVEYORS

721 OLD HIGHWAY 8 N.W.
NEW BRIGHTON, MINNESOTA 55112
651-631-0351
FAX 651-631-8805
email: kemper@pro-ns.net
www.kempersurveys.com

2203 OLIVER AVENUE NORTH

CITY OF MINNEAPOLIS, HENNEPIN COUNTY, MINNESOTA

(EXISTING CONDITIONS MARCH, 2024)



FRONT OF 2203 OLIVER AVENUE NORTH
CITY OF MINNEAPOLIS, HENNEPIN COUNTY, MN

ZONING REQUIREMENTS

ZONED UN2 - URBAN NEIGHBORHOOD DISTRICT

SUBJECT TO BF12 - INTERIOR 2 BUILT FORM OVERLAY DISTRICT

MINIMUM LOT AREA - 5,000 SQ. FT.

MINIMUM LOT WIDTH - 40 FEET

MAXIMUM FLOOR AREA RATIO - 0.5

MAXIMUM LOT COVERAGE - 45%

MAXIMUM IMPERVIOUS SURFACE COVERAGE - 60%

MAXIMUM HEIGHT - 2.5 STORIES, 28 FEET, (THE HIGHEST POINT OF A GABLE, HIP OR GAMBREL ROOF SHALL NOT EXCEED 33 FEET)

BUILDING SETBACKS:

FRONT - 20 FEET (THE REQUIRED FRONT YARD SHALL BE INCREASED WHERE THE ESTABLISHED FRONT YARD OF THE CLOSEST PRINCIPAL BUILDING ORIGINALLY DESIGNED FOR RESIDENTIAL PURPOSES LOCATED ON THE SAME BLOCK FACE ON EITHER SIDE OF THE PROPERTY EXCEEDS THE FRONT YARD REQUIRED BY THE ZONING DISTRICT. IN SUCH CASE, THE REQUIRED FRONT YARD SHALL BE NOT LESS THAN SUCH ESTABLISHED FRONT YARD, PROVIDED THAT WHERE THERE ARE PRINCIPAL BUILDINGS ORIGINALLY DESIGNED FOR RESIDENTIAL PURPOSES ON BOTH SIDES OF THE PROPERTY, THE REQUIRED FRONT YARD SHALL BE NOT LESS THAN THAT ESTABLISHED BY A LINE JOINING THOSE PARTS OF BOTH BUILDINGS NEAREST TO THE FRONT LOT LINE, NOT INCLUDING ANY OBSTRUCTIONS ALLOWED)

SIDE - 5 FEET (HEIGHT LESS THAN 42')
REAR - 5 FEET (HEIGHT LESS THAN 42')

(AS PER CITY OF MINNEAPOLIS ZONING CODE)

ACCESSORY STRUCTURES:

A DETACHED ACCESSORY STRUCTURE SHALL NOT EXCEED 13 FEET. THE WALL HEIGHT SHALL NOT EXCEED 10 FEET AT ANY POINT FROM ADJACENT GRADE TO THE EXTERIOR INTERSECTION OF THE WALL AND THE ROOF RAFTERS FOR HIP, GABLE, GAMBREL, OR FLAT ROOFS AND FOR THE LOW EAVE SIDE FOR SHED ROOFS

THE MAXIMUM FLOOR AREA OF ALL DETACHED ACCESSORY STRUCTURES, AND ANY ATTACHED ACCESSORY USE DESIGNED OR INTENDED TO BE USED FOR THE PARKING OF VEHICLES, SHALL NOT EXCEED 800 SQ. FT. OR 10% OF THE LOT AREA, WHICHEVER IS GREATER

A DETACHED ACCESSORY BUILDING SHALL NOT BE LOCATED CLOSER THAN 6 FEET FROM THE HABITABLE SPACE OF A DWELLING

THE INTERIOR SIDE YARD REQUIREMENT FOR A DETACHED ACCESSORY BUILDING MAY BE REDUCED TO 1 FOOT WHEN THE ENTIRE ACCESSORY BUILDING IS LOCATED IN THE REAR 40 FEET OR REAR 20% OF THE LOT, WHICHEVER IS GREATER, PROVIDED THAT THE ACCESSORY BUILDING SHALL BE LOCATED NOT LESS THAN 10 FEET FROM ANY HABITABLE PORTION OF A PRINCIPAL STRUCTURE ON THE ADJOINING LOT. WHERE THE INTERIOR SIDE YARD IS REDUCED, EAVES, INCLUDING GUTTERS, SHALL NOT BE LESS THAN 6 INCHES FROM THE PROPERTY LINE

THE REAR YARD REQUIREMENT FOR A DETACHED ACCESSORY BUILDING MAY BE REDUCED TO 1 FOOT, EXCEPT WHERE VEHICLE ACCESS DOORS FACE THE REAR LOT LINE, IN WHICH CASE NO REDUCTION OF THE REQUIRED YARD IS PERMITTED. WHERE THE REAR YARD IS REDUCED, EAVES, INCLUDING GUTTERS, SHALL NOT BE LESS THAN 6 INCHES FROM THE PROPERTY LINE

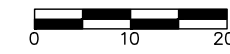
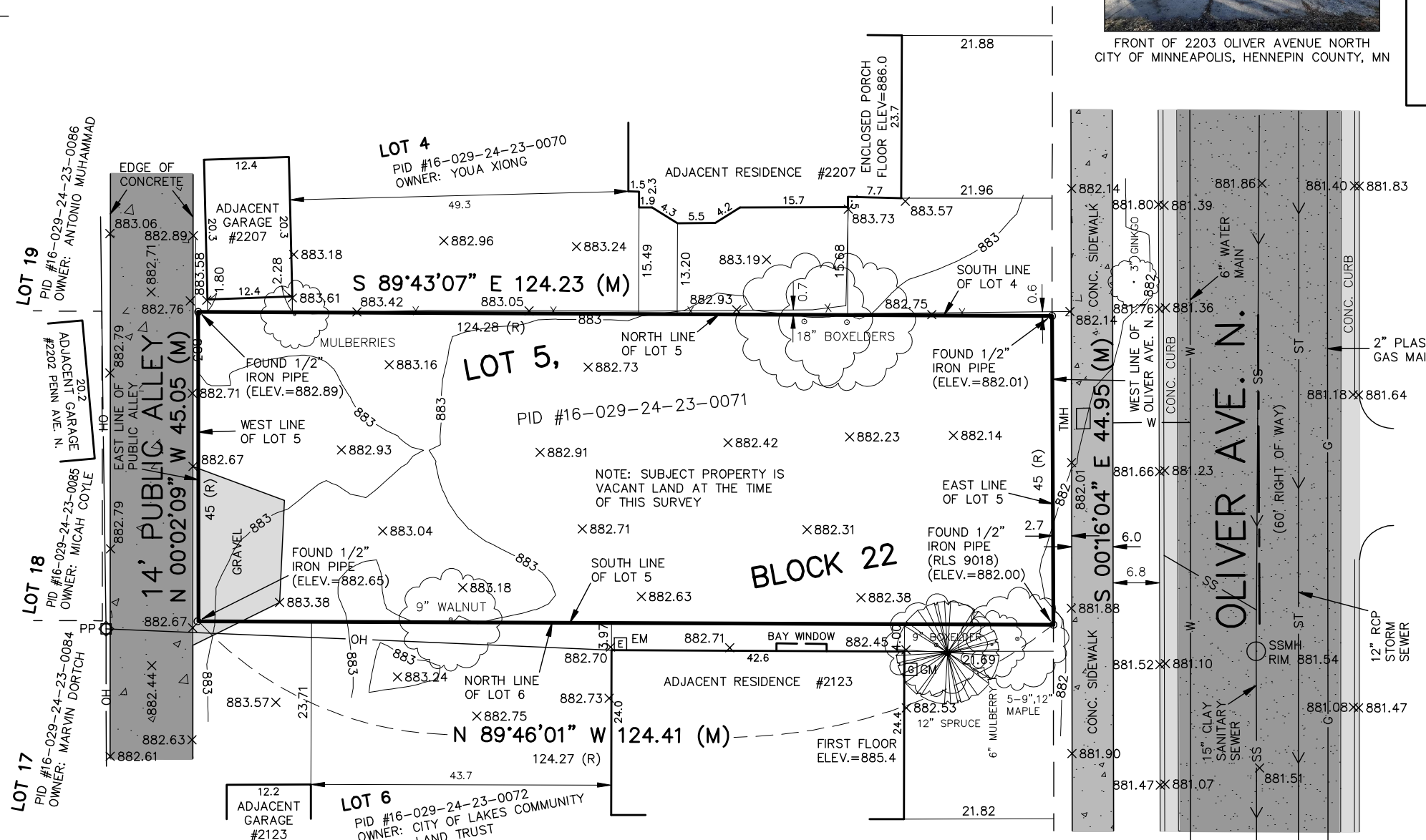

1 INCH EQUALS 20 FEET

BASIS FOR BEARINGS:
HENNEPIN COUNTY
COORDINATE SYSTEM
(NAD83, 1996)

BASIS FOR ELEVATION:
CITY OF MINNEAPOLIS
MONUMENT NO. GPS012
AT THE INTERSECTION
OF 24TH AVE. N. &
IRVING AVE. N.
ELEV.=891.83 (NGVD29)

(VIA REAL TIME GPS
MEASUREMENTS UTILIZING
MINNESOTA DEPARTMENT
OF TRANSPORTATION
VRS NETWORK)

CONTOUR INTERVAL=1/2 FOOT

LEGAL DESCRIPTION

DEED DOC. NO.
A9460716

LOT 005, BLOCK 022,
"FOREST HEIGHTS"

LOT 5 =
5,595 SQ. FT.
OR 0.1284 ACRES



REAR OF 2203 OLIVER AVENUE NORTH
CITY OF MINNEAPOLIS, HENNEPIN COUNTY, MN

PREPARED FOR:
KEVIN GULDEN, PROJECT MANAGER
KATHY WETZEL-MASTEL, EXECUTIVE DIRECTOR
PRG, INC.
2017 38TH ST. E.
MINNEAPOLIS, MINNESOTA 55407
612-721-7556
kevin@prginc.org
kathy@prginc.org
FAX 651-925-0422

LEGEND

- 883 — EXISTING CONTOUR LINE
- × 882.42 EXISTING SPOT ELEVATION
- PP ○ POWER POLE
- SSMH ○ SANITARY SEWER MANHOLE
- EM □ ELECTRIC METER
- GM □ GAS METER
- OH — OVERHEAD UTILITY LINES
- SS — SANITARY SEWER
- W — WATER MAIN/SERVICE
- G — GAS MAIN/SERVICE
- TMH ○ TELEPHONE MANHOLE
- X — CHAIN LINK FENCE
- (M) DENOTES DIMENSION MEASURED DURING THE COURSE OF THIS SURVEY
- (R) DENOTES RECORD DIMENSION AS PER PLAT OF FOREST HEIGHTS
- DENOTES SET SURVEY MONUMENT MARKED "KEMPER 18407"



CERTIFICATION
I HEREBY CERTIFY THAT THIS SURVEY, PLAN, OR REPORT WAS PREPARED BY ME OR UNDER MY DIRECT SUPERVISION AND THAT I AM A DULY LICENSED PROFESSIONAL LAND SURVEYOR UNDER THE LAWS OF THE STATE OF MINNESOTA.

Mark D. Kemper
MARK D. KEMPER, PLS 18407

DATED THIS 15TH DAY OF MARCH, 2024

CERTIFICATE OF SURVEY

24006 (24006.DWG) D.B. TODD HOLEN

July 20, 2021

HGTS Project Number: 21-0444

Mr. Dustin Brandt
City of Minneapolis
Community Planning and Economic Development
105 Fifth Avenue South - 200
Minneapolis, MN 55401

**Re: Geotechnical Exploration Report, Proposed Single Family Home,
2203 Oliver Avenue North, Minneapolis, Minnesota**

Dear Mr. Brandt:

We have completed the geotechnical exploration report for the proposed home at 2203 Oliver Avenue North in Minneapolis, Minnesota. As requested, this cover letter presents the shoring section of our report for use by the City of Minneapolis Planning and Review division.

The planned construction is a single-family residence with a basement level and a detached garage. Based on information provided by the City of Minneapolis Community Planning and Economic Development department we understand that maximum excavations depths for the new home will range from about 7 to 8 feet below the ground surface.

Structure(s) exist on the adjoining properties which appear to have basement levels. That being the case there appears to be limited risk of undermining the foundations to the homes. However, the adjoining property to the north has a fence along the property line which could potentially be impacted by excavation activities and shoring could potentially be required.

We understand the garage will be supported on a thickened edge slab foundation. That also being the case we anticipate excavations for the garage will be less than 5 feet. We understand that under OSHA guidelines shoring is not required for excavations less than 5 feet in depth.

Please see the attached report for specific detail regarding our procedure, results and recommendations for foundation design and construction.

Thank you for the opportunity to assist you on this project. If you have any questions or need additional information, please contact Paul Gionfriddo at 612-729-2959.

Sincerely,

Haugo GeoTechnical Services



Jesse Miller, E.I.T.
Staff Engineer



Paul Gionfriddo, P.E.
Senior Engineer

GEOTECHNICAL EXPLORATION REPORT

PROJECT:

Proposed Single Family Home
2203 Oliver Avenue North
Minneapolis, Minnesota 55411

PREPARED FOR:

City of Minneapolis
Community Planning and Economic Development
105 Fifth Avenue South - 200
Minneapolis, MN 55401

PREPARED BY:

Haugo GeoTechnical Services
2825 Cedar Avenue South
Minneapolis, Minnesota 55407

Haugo GeoTechnical Services Project: 21-0444

July 20, 2021

I hereby certify that this plan, specification, or report was prepared by me or under my direct supervision and that I am a duly Registered Professional Engineer under the laws of the State of Minnesota.



Paul Gionfriddo, P.E.
Senior Engineer
License Number: 23093



Table of Contents

| | | |
|-----|--------------------------------|----|
| 1.0 | INTRODUCTION | 1 |
| 1.1 | Project Description | 1 |
| 1.2 | Purpose | 1 |
| 1.3 | Site Description | 1 |
| 1.4 | Scope of Services | 1 |
| 1.5 | Documents Provided | 1 |
| 1.6 | Locations and Elevations | 2 |
| 2.0 | FIELD PROCEDURES | 2 |
| 3.0 | RESULTS | 3 |
| 3.1 | Soil Conditions | 3 |
| 3.2 | Groundwater | 3 |
| 3.3 | OSHA Soil Classification | 3 |
| 4.0 | DISCUSSION AND RECOMMENDATIONS | 4 |
| 4.1 | Proposed Construction | 4 |
| 4.2 | Discussion | 4 |
| 4.3 | Site Grading Recommendations | 5 |
| 4.4 | Dewatering | 7 |
| 4.5 | Interior Slabs | 7 |
| 4.6 | Below Grade Walls | 7 |
| 4.7 | Exterior Slabs | 8 |
| 4.8 | Site Grading and Drainage | 9 |
| 4.9 | Utilities | 9 |
| 5.0 | CONSTRUCTION CONSIDERATIONS | 9 |
| 5.1 | Excavation | 9 |
| 5.2 | Observations | 10 |
| 5.3 | Backfill and Fills | 10 |
| 5.4 | Testing | 10 |
| 5.5 | Winter Construction | 10 |
| 6.0 | PROCEDURES | 10 |
| 6.1 | Soil Classification | 10 |
| 6.2 | Groundwater Observations | 10 |
| 7.0 | GENERAL | 11 |
| 7.1 | Subsurface Variations | 11 |
| 7.2 | Review of Design | 11 |
| 7.3 | Groundwater Fluctuations | 11 |
| 7.4 | Use of Report | 11 |
| 7.5 | Level of Care | 12 |

APPENDIX

Boring Location Sketch and GPS Boring Locations, Figure 1

Soil Boring Logs, SB-1 and SB-2

Descriptive Terminology

1.0 INTRODUCTION

1.1 Project Description

The City of Minneapolis Community Planning and Economic Development is proposing to construct a new home at 2203 Oliver Avenue North in Minneapolis, Minnesota and retained Haugo GeoTechnical Services (HGTS) to perform a geotechnical exploration to evaluate the suitability of site soil conditions to support the proposed home.

1.2 Purpose

The purpose of this geotechnical exploration was to characterize subsurface soil and groundwater conditions and provide recommendations for foundation design and construction of the proposed home.

1.3 Site Description

The project site is located at 2203 Oliver Avenue North in Minneapolis, Minnesota. At the time of our exploration, the project site existed as a vacant lot that was mostly grass covered. Based on a brief review of historical aerial photographs available on Google Earth, a home formerly existed on the lot that appears to have been removed sometime between September 2009 and May 2010.

The site topography was relatively flat with the elevations at the soil boring locations ranging from about 882 ½ to 883 feet above mean sea level (MSL).

1.4 Scope of Services

Our scope of services was performed in accordance with our contract with the City of Minneapolis Community Planning and Economic Development and limited to the following tasks:

- Completing two (2) standard penetration test soil borings and extending each to nominal depths of 14 ½ feet.
- Obtaining GPS coordinates and ground surface elevations at the soil boring locations.
- Visually/manually classifying samples recovered from the soil borings.
- Preparing soil boring logs describing the materials encountered and the results of groundwater level measurements.
- Preparing an engineering report describing soil and groundwater conditions and providing recommendations for foundation design and construction.

1.5 Documents Provided

We were not provided any architectural, structural or civil engineering plans for this project.

1.6 Locations and Elevations

The soil boring locations were selected by HGTS based on the anticipated construction and site access. The approximate locations of the soil borings are shown on Figure 1, "Soil Boring Location Sketch," in the Appendix. The sketch was prepared by HGTS using an aerial image from Google Earth as a base.

HGTS obtained the GPS coordinates and ground surface elevations at the boring locations using GPS technology based on the MN County Coordinate System (Hennepin County). The GPS coordinates and ground surface elevations are shown on Figure 1 in the Appendix.

2.0 FIELD PROCEDURES

Two (2) standard penetration test borings were advanced on July 16, 2021 by HGTS with a rotary drilling rig, using continuous flight augers to advance the borehole. Representative samples were obtained from the borings, using the split-barrel sampling procedures in general accordance with ASTM Specification D-1586. In the split-barrel sampling procedure, a 2-inch O.D. split-barrel spoon is driven into the ground with a 140-pound hammer falling 30 inches. The number of blows required to drive the sampling spoon the last 12 inches of an 18-inch penetration is recorded as the standard penetration resistance value, or "N" value. The results of the standard penetration tests are indicated on the boring logs. The samples were sealed in containers and provided to HGTS for testing and soil classification.

A field log of each boring was prepared by HGTS. The logs contain visual classifications of the soil materials encountered during drilling, as well as the driller's interpretation of the subsurface conditions between samples and water observation notes. The final boring logs included with this report represents an interpretation of the field logs and include modifications based on visual/manual method observation of the samples.

The soil boring logs, general terminology for soil description and identification, and classification of soils for engineering purposes are also included in the appendix. The soil boring log identify and describe the materials encountered, the relative density or consistency based on the Standard Penetration resistance (N-value, "blows per foot") and groundwater observations.

The strata changes were inferred from the changes in the samples and auger cuttings. The depths shown as changes between strata are only approximate. The changes are likely transitions, variations can occur beyond the location of the boring.

3.0 RESULTS

3.1 Soil Conditions

At the surface, the soil borings encountered about 1 to 1 ½ feet of topsoil/Fill consisting of silty sand that was dark brown in color and contained some roots.

Below the topsoil, the soil borings encountered existing Fill soils consisting of sandy lean clay and clayey sand that extended to depths ranging from about 4 ½ to 7 feet below the ground surface. The existing Fill soils were brown, gray, and black in color.

Penetration resistance values (N-Values), shown as blows per foot (bpf) on the boring logs, within the sandy Fill soils ranged from 4 to 5 bpf, indicating a very loose to loose relative density. N-Values within the clayey Fill soils were 3 bpf, indicating a soft consistency.

The topsoil and Fill materials were underlain by native glacial till soils that extended to the termination depths of the borings. The native glacial till soils consisted of clayey sand and sandy lean clay that were brown and gray in color and contained varying amounts of gravel.

N-Values within the native clayey sand soils were 9 bpf, indicating a loose relative density. N-Values within the native sandy lean clay soils ranged from 6 to 20 bpf, indicating a medium to very stiff consistency.

3.2 Groundwater

Groundwater was not encountered in the soil borings while drilling and sampling or after removal of the auger from the boreholes. Groundwater appears to be below the depths explored by our borings. We do not anticipate that groundwater will be encountered during construction.

Water levels were measured on the dates as noted on the boring logs and the period of water level observations was relatively short. Given the cohesive nature of soils encountered, it is possible that insufficient time was available for groundwater to seep into the borings and rise to its hydrostatic level. Groundwater monitoring wells or piezometers would be required to more accurately determine water levels. Seasonal and annual fluctuations in the groundwater levels should be expected.

3.3 OSHA Soil Classification

At the anticipated excavation depth of 8 feet below the ground surface, the soil borings encountered sandy lean clay and clayey sand, corresponding to the ASTM Classifications of CL and SC, respectively. The clayey sand (SC) will generally be Type C soil under Department of Labor Occupational Safety and Health Administration (OSHA) guidelines, and the sandy lean clay (CL) will generally be Type B soils.

An OSHA-approved qualified person should review the soil classification in the field. Excavations must comply with the requirements of OSHA 29 CFR, Part 1926, Subpart P, "Excavations and Trenches." This document states excavation safety is the responsibility of the contractor. The project specifications should reference these OSHA requirements.

4.0 DISCUSSION AND RECOMMENDATIONS

4.1 Proposed Construction

We were not provided any architectural, structural or civil engineering plans for this project. However, based on correspondence with the City of Minneapolis Community Planning and Economic Development we understand the proposed home will be a 1 ½ story structure on a basement foundation. Maximum excavation depths for the basement were reported to be 8 feet. The new home will also include a 22 foot by 22-foot detached wood framed garage on a thickened perimeter edge slab foundation.

We anticipate the main floor grade will be at or slightly above existing site grade at an elevation of about elevation 885 feet with a basement floor grade at about elevation 877 feet. We anticipate below grade construction consisting of cast-in-place concrete or masonry block foundation walls supported on concrete spread footings. The above grade construction will likely consist of wood framing, a pitched roof and asphalt shingles.

Based on the assumed construction we estimate wall loadings will range from about 2 to 3 kips (2,000 to 3,000 pounds) per lineal foot and column loads, if any will be less than 75 kips (75,000 pounds).

If the proposed loads exceed these values, the proposed grades differ by more than 2 feet from the assumed values or if the design or location of the proposed building changes, we should be informed. Additional analyses and revised recommendations may be necessary.

4.2 Discussion

The lot was vacant at the time of our exploration, however, based on a brief review of historical aerial photographs available on Google Earth a home existed on the site that was removed/demolished sometime between September 2009 and May 2010. Although our soil borings did not encounter remnants of the former structure(s) there is the potential to encounter building remnants or other debris during construction. We recommend that all remnants of any former structure(s), if encountered, including; foundations, foundation walls, floor slabs and any underground utilities be removed from within the proposed building and oversize areas and be properly disposed of off-site.

The vegetation and topsoil are compressible and are not suitable for foundation support will need to be removed from within the building and oversize areas and replaced as needed with suitable compacted engineered fill.

The origin of the Fill encountered in the soil borings is unknown but could be associated with construction or demolition of the structure(s) that formerly existed on the site. The Fill had a loose relative density or soft consistency and portions of the Fill were black in color which indicate organic soils or organic material within the soil. Organic soil or soil containing organic material are generally compressible and settle unfavorably under the structural loads associated with the new home. The Fill is not suitable for foundation support and we recommend that it be removed and replaced with suitable compacted engineered. Portions of

the Fill, quantity unknown, might be suitable for reuse provided it is free of debris or any soft or otherwise unsuitable materials. Some moisture conditioning (wetting or drying) of the soils could be required. Further the Fill, if reused, will need to be compacted to densities meeting project specifications.

Since the new home will include a basement then removal of the vegetation, topsoil, and Fill will likely be incidental to construction.

It is our opinion that the underlying native glacial till soils are suitable for foundation support. Soils that will excavated and reused as fill or backfill could require some moisture conditioning (wetting or drying) to meet the recommended compaction levels. Summer months are typically more favorable for drying wet soils.

Groundwater was not encountered in the borings while drilling and sampling or after removal of the auger from the boreholes. We do not anticipate that groundwater will be encountered during construction.

With the building pads prepared as recommended, it is our opinion the footings can be designed for a net allowable bearing pressure up to 2,000 pounds per square foot (psf).

The following sections provide recommendations for foundation design and construction.

4.3 Site Grading Recommendations

Excavation We recommend that all vegetation, topsoil, Fill, and any soft or otherwise unsuitable soils, if encountered, be removed from below the proposed building and oversize areas. We recommend that all remnants of former structures such as footings, floor slabs, foundation walls and underground utilities, if encountered, be removed from within the buildings and oversize areas. Any loose soils or soils disturbed during excavation activities should be surface compacted to increase their density and uniformity prior to engineered fill and/or footing placement. Table 1 below summarizes the anticipated excavation depths at the soil boring locations. Excavation depths may vary and could be deeper.

Table 1. Anticipated Excavation Depths

| Boring Number | Measured Surface Elevation (feet) | Anticipated Excavation Depth (feet)* | Anticipated Excavation Elevation (feet)* |
|---------------|-----------------------------------|--------------------------------------|--|
| SB-1 | 882.4 | 4 ½ | 878 |
| SB-2 | 883.2 | 7 | 876 |

* = Excavation depths and elevations were rounded to nearest ½ foot.

Oversizing In areas where the excavations extend below the proposed footing elevations, the excavations require oversizing. We recommend the perimeter of the excavation be extended a foot outside the proposed footprint for every foot below footing grade (1H:1V oversizing). The purpose of the oversizing is to provide lateral support of the foundation.

Shoring The planned construction is a single-family residence with a basement and detached garage. Structure(s) exist on the adjoining properties which appear to have basement levels. That being the case there appears to be limited risk of undermining the foundations to the homes. However, the adjoining property to the north has a fence along the property line which could potentially be impacted by excavation activities and shoring could potentially be required.

We understand the garage will be supported on a thickened edge slab foundation. That being the case we anticipate excavations for the garage will be less than 5 feet. We understand that under OSHA guidelines shoring is not required for excavations less than 5 feet in depth.

The contractor should be aware that steep cuts, if any, in the soils will generally ravel and flatten over time. Excavations should be backfilled as soon as practical and the adjoining properties should be closely observed for deformation.

HGTS is available for consultation and site observations at the time of the excavation, for an additional fee, upon request by either the City of Minneapolis or the contractor or developer.

Fill Material Fill required to attain site grades may consist of any debris-free, non-organic mineral soil. Except we recommend that fill or backfill placed in wet excavations or within 2 feet of the groundwater table, if encountered, consist of granular soil (sand) with less than 5 percent passing the number 200 sieve and at least 50 percent retained on the number 40 sieve.

Portions of the Fill, quantity unknown, excavated during foundation construction might be suitable for reuse provided it is free of debris or other unsuitable materials. However, the soils could require some moisture conditioning (wetting or drying) to meet the recommend compaction levels.

The native glacial till soils, excavated during foundation construction appear to be generally suitable for reuse as structural fill or backfill. Soils that will be reused as fill or backfill could require some moisture conditioning (wetting or drying) to meet the recommend compaction levels. Summer months are typically more favorable for drying wet soils.

Topsoil or soils that are black in color are not suitable for reuse as structural fill or backfill.

Backfilling We recommend that backfill placed to attain site grades be compacted to a minimum of 95 percent of its standard Proctor density (ASTM D 698). Granular fill classified as SP or SP-SM should be placed within 65 percent to 105 percent of its optimum moisture content as determined by the standard Proctor. Other fill soils should be placed within 3 percentage points above and 1 percentage point below its optimum moisture content as determined by the standard Proctor. All fill should be placed in thin lifts and be compacted with a large self-propelled vibratory compactor operating in vibratory mode.

Foundations We recommend the perimeter footings bear a minimum of 42 inches below the exterior grade for frost protection. Interior footings may be placed immediately below the slab provided construction does not occur during below freezing weather conditions. Foundation elements in unheated areas (i.e., deck or porch footings) should bear at least 5 feet below exterior grade for frost protection.

We anticipate the foundations and floor slabs will bear on compacted engineered fill or native glacial till soils. With the building pad prepared as recommended, it is our opinion the footings can be designed for a net allowable bearing pressure up to 2,000 pounds per square foot (psf).

We anticipate total and differential settlement of the foundations will be less than 1 inch and ½ inch, respectively, across a 30-foot span.

4.4 Dewatering

Groundwater was not encountered in the soil borings while drilling and sampling or after removal of the auger from the boreholes. We do not anticipate that groundwater will be encountered and do not anticipate that dewatering will be required.

4.5 Interior Slabs

The anticipated floor subgrade will consist of compacted clayey engineered fill or clayey native glacial till soils. It is our opinion a modulus of subgrade reaction, k, of 100 pounds per square inch per inch (psi/inch) of deflection may be used to design the floor.

If floor coverings or coatings less permeable than the concrete slab will be used, we recommend that a vapor retarder or vapor barrier be placed immediately beneath the slab. Some contractors prefer to bury the vapor barrier or vapor retarder beneath a layer of sand to reduce curling and shrinkage, but this practice often traps water between the slab and vapor retarder or barrier. Regardless of where the vapor retarder or vapor barrier is placed, we recommend consulting the floor covering manufacturer regarding the appropriate type, use and installation of the vapor retarder or vapor barrier to preserve the warranty.

We recommend following all state and local building codes with regards to a radon mitigation plan beneath interior slabs.

4.6 Below Grade Walls

We recommend general waterproofing of the below grade walls. We recommend either placing drainage composite against the backs of the exterior walls or backfilling adjacent to the walls with sand having less than 50 percent of the particles by weight passing the #40 sieve and less than 5 percent of the particles by weight passing the #200 sieve. The sand backfill should be placed within 2 feet horizontally of the wall. We recommend the balance of the backfill for the walls consist of sand however the sand may contain up to 20 percent of the particles by weight passing the #200 sieve.

We recommend installing drain tile behind the below grade walls, adjacent to the wall footing and below the slab elevation. Preferably the drain tile should consist of perforated pipe embedded in gravel. A geotextile filter fabric should encase the pipe and gravel. The drain tile should be routed to a storm sewer, sump pump or other suitable disposal site.

Foundation walls or below grade (basement) walls will have lateral loads from the surrounding soil transmitted to them. Active earth pressures can be used to design the below grade walls if the walls are allowed to rotate slightly. If wall rotation cannot be tolerated, then

below grade wall design should be based on at-rest earth pressures. It is our opinion that the estimated soil parameters presented in Table 2 can be used for below grade wall design. These estimated soil parameters are based on the assumptions that the walls are drained, there are no surcharge loads within a horizontal distance equal to the height of the wall and the backfill is level.

Table 2. Estimated Soil Parameters

| Soil Type | Estimated Unit Weight (pcf) | Estimated Friction Angle (degrees) | At-Rest Pressure (pcf) | Active Soil Pressure (pcf) | Passive Soil Pressure (pcf) |
|----------------------|-----------------------------|------------------------------------|------------------------|----------------------------|-----------------------------|
| Sand (SP & SP-SM) | 120 | 32 | 55 | 35 | 390 |
| Other Soils (SC, CL) | 135 | 28 | 70 | 50 | 375 |

Resistance to lateral earth pressures will be provided by passive resistance against the wall footings and by sliding resistance along the bottom of the wall footings. We recommend a sliding coefficient of 0.35. This value does not include a factor of safety.

4.7 Exterior Slabs

Exterior slabs will likely be underlain by clayey soils which are considered moderately to highly frost susceptible. If these soils become saturated and freeze, frost heave may occur. This heave can be a nuisance in front of doors and at other critical grade areas. One way to help reduce the potential for heaving is to remove the frost-susceptible soils below the slabs down to bottom of footing grades and replace them with non-frost-susceptible backfill consisting of sand having less than 5 percent of the particles by weight passing the number 200 sieve.

If this approach is used and the excavation bottoms terminate in non-free draining granular soil, we recommend a drain tile be installed along the bottom outer edges of the excavation to collect and remove any water that may accumulate within the sand. The bottom of the excavation should be graded away from the building.

If the banks of the excavations to remove the frost-susceptible soils are not sloped, abrupt transitions between the frost-susceptible and non-frost-susceptible backfill will exist along which unfavorable amounts of differential heaving may occur. Such transitions could exist between exterior slabs and sidewalks, between exterior slabs and pavements and along the slabs themselves if the excavations are confined to only the building entrances. To address this issue, we recommend sloping the excavations to remove frost-susceptible soils at a minimum 3:1 (horizontal:vertical) gradient.

An alternative method of reducing frost heave is to place a minimum of 2 inches of extruded polystyrene foam insulation beneath the slabs and extending it about 4 feet beyond the slabs. The insulation will reduce frost penetration into the underlying soil and reduce heave. Six to twelve inches of granular soil is typically placed over the insulation to protect it during construction.

Another alternative for reducing frost heave is to support the slabs on frost depth footings. A void space of at least 4 inches should be provided between the slab and the underlying soil to allow the soil to heave without affecting the slabs.

4.8 Site Grading and Drainage

We recommend the site be graded to provide positive run-off away from the proposed house. We recommend landscaped areas be sloped a minimum of 6 inches within 10 feet of the building and slabs be sloped a minimum of 2 inches. In addition, we recommend downspouts with long splash blocks or extensions.

We recommend the lowest floor grades be constructed to maintain at least a 2-foot separation between the lowest floor slab and the 100-year flood level of nearby wetlands, storm water ponds or other surface water features.

4.9 Utilities

We anticipate that new utilities could be installed as part of this project. We further anticipate that new utilities will bear at depths ranging from about 7 to 10 feet below the ground surface. At these depths, we anticipate that the pipes will bear on compacted engineered fill or native glacial till soils which in our opinion are suitable for utility support.

We recommend bedding material be thoroughly compacted around the pipes. We recommend trench backfill above the pipes be compacted to a minimum of 95 percent beneath slabs and pavements, the exception being within 3 feet of the proposed pavement subgrade, where 100 percent of standard Proctor density is required. In landscaped areas, we recommend a minimum compaction of 90 percent.

Groundwater was not encountered in the soil borings. We do not anticipate that groundwater will be encountered during utility construction and do not anticipate that dewatering will be required.

5.0 CONSTRUCTION CONSIDERATIONS

5.1 Excavation

At the anticipated excavation depth of 8 feet below the ground surface, the soil borings encountered sandy lean clay and clayey sand, corresponding to the ASTM Classifications of CL and SC, respectively. The clayey sand (SC) will generally be Type C soil under Department of Labor Occupational Safety and Health Administration (OSHA) guidelines, and the sandy lean clay (CL) will generally be Type B soils.

Temporary excavations in Type C soils should be constructed at a minimum of 1 ½ foot horizontal to every 1-foot vertical within excavations. Temporary excavations in Type B soils should be constructed at a minimum of 1-foot horizontal to every 1-foot vertical within excavations. Slopes constructed in this manner may still exhibit surface sloughing. If site constraints do not allow the construction of slopes with these dimensions, then temporary shoring may be required.

5.2 Observations

A geotechnical engineer or qualified engineering technician should observe the excavation subgrade to evaluate if the subgrade soils are similar to those encountered in the borings and adequate to support the proposed construction.

5.3 Backfill and Fills

We recommend moisture conditioning all soils that will be used as fill or backfill in accordance with Section 4.3 above. We recommend that fill and backfill be placed in lifts not exceeding 4 to 12 inches, depending on the size of the compactor and materials used.

5.4 Testing

We recommend density tests of backfill and fills placed for the proposed house foundations. Samples of the proposed materials should be submitted to our laboratory prior to placement for evaluation of their suitability and to determine their optimum moisture content and maximum dry density (Standard Proctor).

5.5 Winter Construction

If site grading and construction is anticipated to proceed during cold weather, all snow and ice should be removed from cut and fill areas prior to additional grading and placement of fill. No fill should be placed on frozen soil and no frozen soil should be used as fill or backfill.

Concrete delivered to the site should meet the temperature requirements of ASTM and/or ACI. Concrete should not be placed on frozen soil. Concrete should be protected from freezing until the necessary strength is obtained. Frost should not be permitted to penetrate below the footings.

6.0 PROCEDURES

6.1 Soil Classification

The drill crew chief visually and manually classified the soils encountered in the borings in general accordance with ASTM D 2488, "Description and Identification of Soils (Visual-Manual Procedure)." Soil terminology notes are included in the Appendix. The samples were returned to our laboratory for review of the field classification by a soils engineer. Samples will be retained for a period of 30 days.

6.2 Groundwater Observations

Immediately after taking the final samples in the bottom of the boring, the hole was checked for the presence of groundwater. Immediately after removing the augers from the borehole the hole was once again checked and the depth to water and cave-in depths were noted.

7.0 GENERAL

7.1 Subsurface Variations

The analyses and recommendations presented in this report are based on data obtained from a limited number of soil borings. Variations can occur away from the boring, the nature of which may not become apparent until additional exploration work is completed, or construction is conducted. A reevaluation of the recommendations in this report should be made after performing on-site observations during construction to note the characteristics of any variations. The variations may result in additional foundation costs and it is suggested that a contingency be provided for this purpose.

It is recommended that we be retained to perform the observation and testing program during construction to evaluate whether the design is as expected, if any design changes have affected the validity of our recommendations, and if our recommendations have been correctly interpreted and implemented in the designs, specifications and construction methods. This will allow correlation of the soil conditions encountered during construction to the soil borings and test pits and will provide continuity of professional responsibility.

7.2 Review of Design

This report is based on the design of the proposed structures as related to us for preparation of this report. It is recommended that we be retained to review the geotechnical aspects of the design and specifications. With the review, we will evaluate whether any changes have affected the validity of the recommendations and whether our recommendations have been correctly interpreted and implemented in the design and specifications.

7.3 Groundwater Fluctuations

We made water level measurements in the borings at the times and under the conditions stated on the boring log. The data was interpreted in the text of this report. The period of observation was relatively short and fluctuations in the groundwater level may occur due to rainfall, flooding, irrigation, spring thaw, drainage, and other seasonal and annual factors not evident at the time the observations were made. Design drawings and specifications and construction planning should recognize the possibility of fluctuations.

7.4 Use of Report

This report is for the exclusive use of the City of Minneapolis Community Planning and Economic Development and their design team to use to design the proposed structures and prepare construction documents. In the absence of our written approval, we make no representation and assume no responsibility to other parties regarding this report. The data, analysis and recommendations may not be appropriate for other structures or purposes. We recommend that parties contemplating other structures or purposes contact us.

7.5 Level of Care

Haugo GeoTechnical Services has used the degree of skill and care ordinarily exercised under similar circumstance by members of the profession currently practicing in this locality. No warranty expressed or implied is made.

APPENDIX



Legend

 Approximate Soil Boring Location



GPS Boring Locations

| Boring Number | Elevation (Feet) | Northing Coordinate | Easting Coordinate |
|---------------|------------------|---------------------|--------------------|
| SB-1 | 882.4 | 176703.262 | 519702.388 |
| SB-2 | 883.2 | 176704.32 | 519672.944 |

Referencing Minnesota County Coordinates Basis – Hennepin County

Disclaimer: Map and parcel data are believed to be accurate, but accuracy is not guaranteed. This is not a legal document and should not be substituted for a title search, appraisal, survey, or for zoning verification.

Haugo GeoTechnical Services, LLC
 2825 Cedar Avenue S.
 Minneapolis, MN 55407

Soil Boring Location Sketch
 2203 Oliver Avenue N
 Minneapolis, MN

Figure #: 1
 Drawn By: NA
 Date: 7/19/2021
 Scale: None
 Project #: 21-0444



Haugo GeoTechnical Services
 2825 Cedar Ave South
 Minneapolis, MN 55407
 Telephone: 612-729-2959
 Fax: 763-445-2238

BORING NUMBER 1

CLIENT City of Minneapolis
PROJECT NUMBER 21-0444
DATE STARTED 7/16/21 **COMPLETED** 7/16/21
DRILLING CONTRACTOR HGTS - 120
DRILLING METHOD Hollow Stem Auger/Split Spoon
LOGGED BY MS **CHECKED BY** PG
NOTES _____

PROJECT NAME 2203 Oliver Avenue North
PROJECT LOCATION Minneapolis, MN
GROUND ELEVATION 884 ft **HOLE SIZE** 3 1/4 inches
GROUND WATER LEVELS:
AT TIME OF DRILLING --- Not Encountered
AT END OF DRILLING ---
AFTER DRILLING --- Not Encountered with Cave-In Depth of 3 Feet

GEOTECH BH PLOTS - GINT STD US LAB.GDT - 7/20/21 12:36 - C:\USERS\HGTS\3DROPOBOX (HGTS)\HAUGO GEOTECHNICAL SERVICES\GINT PROJECT BACKUP\PROJECTS\21-0444 2203 OLIVER AVENUE NORTH.GPJ

| DEPTH (ft) | GRAPHIC LOG | MATERIAL DESCRIPTION | SAMPLE TYPE NUMBER | RECOVERY % (RQD) | BLOW COUNTS (N VALUE) | MOISTURE CONT. (%) | NOTES | ▲ SPT N VALUE ▲ | | |
|------------|-------------|--|--------------------|------------------|-----------------------|--------------------|-------|-----------------|----|----|
| | | | | | | | | 20 | 40 | 60 |
| 0.0 | | Silty Sand, trace Roots, dark brown, moist. (Topsoil/Fill) | AU 8 | | | | | | | |
| 2.5 | | Sandy Lean Clay, trace Gravel, brown and black, wet. (Fill) | SS 9 | | 2-1-2 (3) | | | | | |
| 5.0 | | (SC) Clayey Sand, fine to medium grained, fine to medium grained, trace Gravel, brown and gray, moist, loose. (Glacial Till) | SS 10 | | 3-4-5 (9) | | | | | |
| 7.5 | | (CL) Sandy Lean Clay, trace Gravel, brown, gray, wet, rather stiff. (Glacial Till) | SS 11 | | 4-4-6 (10) | | | | | |
| 10.0 | | | SS 12 | | 3-4-5 (9) | | | | | |
| 12.5 | | | SS 13 | | 4-3-6 (9) | | | | | |
| | | (CL) Sandy Lean Clay, trace Gravel, gray, wet, very stiff. (Glacial Till) | SS 14 | | 5-8-12 (20) | | | | | |

Bottom of borehole at 14.5 feet.



Haugo GeoTechnical Services
 2825 Cedar Ave South
 Minneapolis, MN 55407
 Telephone: 612-729-2959
 Fax: 763-445-2238

BORING NUMBER 2

CLIENT City of Minneapolis
PROJECT NUMBER 21-0444
DATE STARTED 7/16/21 **COMPLETED** 7/16/21
DRILLING CONTRACTOR HGTS - 120
DRILLING METHOD Hollow Stem Auger/Split Spoon
LOGGED BY MS **CHECKED BY** PG
NOTES _____

PROJECT NAME 2203 Oliver Avenue North
PROJECT LOCATION Minneapolis, MN
GROUND ELEVATION 883.7 ft **HOLE SIZE** 3 1/4 inches
GROUND WATER LEVELS:
AT TIME OF DRILLING --- Not Encountered
AT END OF DRILLING ---
AFTER DRILLING --- Not Encountered with Cave-In Depth of 5 Feet

GEOTECH BH PLOTS - GINT STD US LAB.GDT - 7/20/21 12:36 - C:\USERS\HGTS\3DROPOBOX (HGTS)\HAUGO GEOTECHNICAL SERVICES\GINT PROJECT BACKUP\PROJECTS\21-0444 2203 OLIVER AVENUE NORTH.GPJ

| DEPTH (ft) | GRAPHIC LOG | MATERIAL DESCRIPTION | SAMPLE TYPE NUMBER | RECOVERY % (RQD) | BLOW COUNTS (N VALUE) | MOISTURE CONT. (%) | NOTES | ▲ SPT N VALUE ▲ | | | |
|------------|-------------|--|--------------------|------------------|-----------------------|--------------------|-------|-----------------------|----|----|----|
| | | | | | | | | PL | MC | LL | |
| | | | | | | | | □ FINES CONTENT (%) □ | | | |
| | | | | | | | | 20 | 40 | 60 | 80 |
| 0.0 | | Silty Sand, trace Roots, dark brown, moist. (Topsoil/Fill) | AU 1 | | | | | | | | |
| 2.5 | | Clayey Sand, trace Gravel, brown and gray, moist. (Fill) | SS 2 | | 2-2-3 (5) | | | | | | |
| 5.0 | | | SS 3 | | 2-1-3 (4) | | | | | | |
| 7.5 | | (CL) Sandy Lean Clay, trace Gravel, brown, wet, medium to rather stiff. (Glacial Till) | SS 4 | | 4-4-4 (8) | | | | | | |
| 10.0 | | | SS 5 | | 2-3-3 (6) | | | | | | |
| 12.5 | | | SS 6 | | 3-4-7 (11) | | | | | | |
| | | | SS 7 | | 7-2-8 (10) | | | | | | |

61

Bottom of borehole at 14.5 feet.



| Criteria for Assigning Group Symbols and Group Names Using Laboratory Tests ^a | | | | Soils Classification | |
|--|---|--|---|--|-----------------------------------|
| | | | | Group Symbol | Group Name ^b |
| Coarse-grained Soils more than 50% retained on No. 200 sieve | Gravels More than 50% of coarse fraction retained on No. 4 sieve | Clean Gravels 5% or less fines ^e | $C_u \geq 4$ and $1 \leq C_c \leq 3$ ^c | GW | Well-graded gravel ^d |
| | | Gravels with Fines More than 12% fines ^e | $C_u < 4$ and/or $1 > C_c > 3$ ^c | GP | Poorly graded gravel ^d |
| | | | Fines classify as ML or MH | GM | Silty gravel ^{d f g} |
| | | Sands 50% or more of coarse fraction passes No. 4 sieve | Clean Sands 5% or less fines ⁱ | $C_u \geq 6$ and $1 \leq C_c \leq 3$ ^c | SW |
| | Sands with Fines More than 12% ⁱ | | $C_u < 6$ and/or $1 > C_c > 3$ ^c | SP | Poorly graded sand ^h |
| | | | Fines classify as ML or MH | SM | Silty sand ^{f g h} |
| | Fines classify as CL or CH | | SC | Clayey sand ^{f g h} | |
| | Fine-grained Soils 50% or more passed the No. 200 sieve | Silts and Clays Liquid limit less than 50 | Inorganic | PI > 7 and plots on or above "A" line ^j | CL |
| PI < 4 or plots below "A" line ^j | | | | ML | Silt ^{k i m} |
| Organic | | Liquid limit - oven dried < 0.75 | OL | Organic clay ^{k i m n} | |
| | | Liquid limit - not dried < 0.75 | OL | Organic silt ^{k i m o} | |
| Silts and clays Liquid limit 50 or more | | Inorganic | PI plots on or above "A" line | CH | Fat clay ^{k i m} |
| | | | PI plots below "A" line | MH | Elastic silt ^{k i m} |
| | Organic | Liquid limit - oven dried < 0.75 | OH | Organic clay ^{k i m p} | |
| | | Liquid limit - not dried < 0.75 | OH | Organic silt ^{k i m q} | |
| Highly Organic Soils | Primarily organic matter, dark in color and organic odor | | | PT | Peat |

Particle Size Identification

| | | |
|----------|-------|---|
| Boulders | | over 12" |
| Cobbles | | 3" to 12" |
| Gravel | | |
| Coarse | | 3/4" to 3" |
| Fine | | No. 4 to 3/4" |
| Sand | | |
| Coarse | | No. 4 to No. 10 |
| Medium | | No. 10 to No. 40 |
| Fine | | No. 40 to No. 200 |
| Silt | | $<$ No. 200, PI $<$ 4 or below "A" line |
| Clay | | $<$ No. 200, PI \geq 4 and on or above "A" line |

Relative Density of Cohesionless Soils

| | | |
|--------------|-------|--------------|
| Very loose | | 0 to 4 BPF |
| Loose | | 5 to 10 BPF |
| Medium dense | | 11 to 30 BPF |
| Dense | | 31 to 50 BPF |
| Very dense | | over 50 BPF |

Consistency of Cohesive Soils

| | | |
|--------------|-------|--------------|
| Very soft | | 0 to 1 BPF |
| Soft | | 2 to 3 BPF |
| Rather soft | | 4 to 5 BPF |
| Medium | | 6 to 8 BPF |
| Rather stiff | | 9 to 12 BPF |
| Stiff | | 13 to 16 BPF |
| Very stiff | | 17 to 30 BPF |
| Hard | | over 30 BPF |

- a. Based on the material passing the 3-in (75mm) sieve.
- b. If field sample contained cobbles or boulders, or both, add "with cobbles or boulders or both" to group name.
- c. $C_u = D_{60} / D_{10}$, $C_c = (D_{30})^2 / (D_{10} \times D_{60})$
- d. If soil contains $\geq 15\%$ sand, add "with sand" to group name.
- e. Gravels with 5 to 12% fines require dual symbols:
 GW-GM well-graded gravel with silt
 GW-GC well-graded gravel with clay
 GP-GM poorly graded gravel with silt
 GP-GC poorly graded gravel with clay
- f. If fines classify as CL-ML, use dual symbol GC-GM or SC-SM.
- g. If fines are organic, add "with organic fines" to group name.
- h. If soil contains $\geq 15\%$ gravel, add "with gravel" to group name.
- i. Sands with 5 to 12% fines require dual symbols:
 SW-SM well-graded sand with silt
 SW-SC well-graded sand with clay
 SP-SM poorly graded sand with silt
 SP-SC poorly graded sand with clay
- j. If Atterberg limits plot in hatched area, soil is a CL-ML, silty clay.
- k. If soil contains 10 to 29% plus No. 200, add "with sand" or "with gravel" whichever is predominant.
- l. If soil contains $\geq 30\%$ plus No. 200, predominantly sand, add "sandy" to group name.
- m. If soil contains $\geq 30\%$ plus No. 200 predominantly gravel, add "gravelly" to group name.
- n. PI ≥ 4 and plots on or above "A" line.
- o. PI < 4 or plots below "A" line.
- p. PI plots on or above "A" line.
- q. PI plots below "A" line.

Drilling Notes

Standard penetration test borings were advanced by 3 1/4" or 6 1/4" ID hollow-stem augers unless noted otherwise. Jetting water was used to clean out auger prior to sampling only where indicated on logs. Standard penetration test borings are designated by the prefix "ST" (Split Tube). All samples were taken with the standard 2" OD split-tube sampler, except where noted.

Power auger borings were advanced by 4" or 6" diameter continuous-flight, solid-stem augers. Soil classifications and strata depths were inferred from disturbed samples augered to the surface and are, therefore, somewhat approximate. Power auger borings are designated by the prefix "B."

Hand auger borings were advanced manually with a 1 1/2" or 3 1/4" diameter auger and were limited to the depth from which the auger could be manually withdrawn. Hand auger borings are indicated by the prefix "H."

BPF: Numbers indicate blows per foot recorded in standard penetration test, also known as "N" value. The sampler was set 6" into undisturbed soil below the hollow-stem auger. Driving resistances were then counted for second and third 6" increments and added to get BPF. Where they differed significantly, they are reported in the following form: 2/12 for the second and third 6" increments, respectively.

WH: WH indicates the sampler penetrated soil under weight of hammer and rods alone; driving not required.

WR: WR indicates the sampler penetrated soil under weight of rods alone; hammer weight and driving not required.

TW indicates thin-walled (undisturbed) tube sample.

Note: All tests were run in general accordance with applicable ASTM standards.

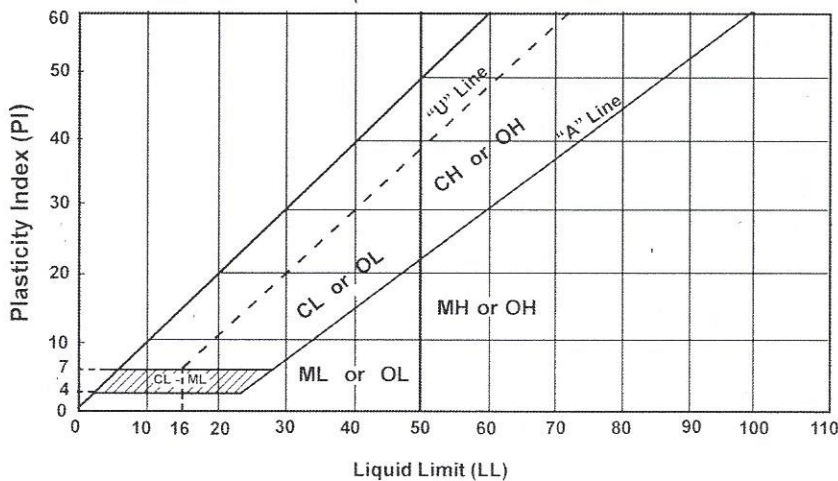

Laboratory Tests

| | | | |
|------|-----------------------------|--------|--------------------------------------|
| DD | Dry density, pcf | OC | Organic content, % |
| WD | Wet density, pcf | S | Percent of saturation, % |
| MC | Natural moisture content, % | SG | Specific gravity |
| LL | Liquid limit, % | C | Cohesion, psf |
| PL | Plastic limit, % | ϕ | Angle of internal friction |
| PI | Plasticity index, % | qu | Unconfined compressive strength, psf |
| P200 | % passing 200 sieve | qp | Pocket penetrometer strength, tsf |